

Dec. 2009



# SERVICE MANUAL ADDENDUM

---

## IC-F4001/F4002/F4003/F4006/F4008

---

### CONTENTS

PARTS LIST .....	1
BOARD LAYOUTS .....	7
VOLTAGE DIAGRAM .....	9











[MAIN-A UNIT]

REF NO.	PARTS NO.	DESCRIPTION	M.	H/V LOCATION
C421	4030019930	S.CER C1005 JB 1A 104K-T	T	75.4/12
C423	4030019810	S.CER C1005 JB 1E 103K-T	B	65.2/38.4
C424	4030019740	S.CER C1005 JB 1H 102K-T	T	63.8/34.4
C426	4030019810	S.CER C1005 JB 1E 103K-T	B	69/30.3
C427	4030019930	S.CER C1005 JB 1A 104K-T	T	73.7/26
C429	4030019810	S.CER C1005 JB 1E 103K-T	B	77.2/25.7
C430	4030019930	S.CER C1005 JB 1A 104K-T	T	65.9/11.4
C431	4510009870	S.ELE 10 CE 100 LD	T	14.7/27.1
C432	4030019740	S.CER C1005 JB 1H 102K-T	T	14.3/31.7
C433	4030019930	S.CER C1005 JB 1A 104K-T	T	16.2/32.2
C434	4030019810	S.CER C1005 JB 1E 103K-T	T	14.3/32.6
C435	4030019740	S.CER C1005 JB 1H 102K-T	T	18/32.2
C436	4550007320	S.TAN F930J226MAABMA	B	85.2/44.4
C437	4030019930	S.CER C1005 JB 1A 104K-T	T	17.1/32.2
C448	4030019490	S.CER C2012 JB 1A 106K-T	B	29/46
C451	4030009790	S.CER C1005 CH 1H 330J-T	B	86.6/38.5
C452	4030009740	S.CER C1005 CH 1H 100C-T	B	86.1/37.3
C453	4030009770	S.CER C1005 CH 1H 220J-T	B	87/35.2
C454	4030019930	S.CER C1005 JB 1A 104K-T	B	86.1/32.2
C456	4030019930	S.CER C1005 JB 1A 104K-T	B	87.9/32.2
C457	4030019870	S.CER C1005 JB 1A 273K-T	B	86.8/46.9
C458	4030019930	S.CER C1005 JB 1A 104K-T	T	84.7/45.5
C459	4030019930	S.CER C1005 JB 1A 104K-T	B	85.2/40.6
C460	4030019930	S.CER C1005 JB 1A 104K-T	B	79.5/46.1
C461	4030019930	S.CER C1005 JB 1A 104K-T	B	80.4/46.1
C462	4030019930	S.CER C1005 JB 1A 104K-T	B	81.3/46.1
C465	4030019930	S.CER C1005 JB 1A 104K-T	T	77.4/35
C466	4030019810	S.CER C1005 JB 1E 103K-T	T	79/35
C467	4030019930	S.CER C1005 JB 1A 104K-T	B	85.2/32.2
J53	6510021901	S.CON BM02B-ASRS-TF(LF)(SN)	T	27.9/34.4
F51	5210000970	S.FUS ERBSE3R00U	T	10.7/37.6
DS51	5040002670	S.LED CL-165HR/YG	T	2.6/37.9
MC51	7700002920	MIC EM9745P-38-G-01 <HOR>		
S51	2260001900	SWI SW-149 (SKHLLD)		
S52	2260002800	S.SWI SW-167 (SKQTLAE010)	B	39.2/1.8
S53	2260002800	S.SWI SW-167 (SKQTLAE010)	B	48.7/1.8
S54	2250000670	ENC TP70TF5169-15.9F-3285		
EP3	6910018460	S.BEA MMZ1005Y102C-T	T	63.7/19.3
EP4	6910018460	S.BEA MMZ1005Y102C-T	T	41.9/19.4
EP5	6910018460	S.BEA MMZ1005Y102C-T	T	41/10.9
EP6	6910014730	S.BEA MPZ2012S331A-T	B	22.4/17
EP11	6910021240	S.BEA MMZ1005A152ET	T	54.9/24.5
EP14	6910021240	S.BEA MMZ1005A152ET	T	60.4/22.2
EP51	6910018460	S.BEA MMZ1005Y102C-T	B	19.1/46.2
MP3	8510016471	S.CAS 2775 VCO CASE-1	T	58.8/23.2
MP4	6910014760	S.PLA OG-503040	B	66.8/18.4
MP5	6910014760	S.PLA OG-503040	B	17.2/8.4
MP51	6910014760	S.PLA OG-503040 [EUR-23]	B	22.2/45.3
	6910014760	S.PLA OG-503040 [UK-03]		

M.=Mounted side (T: Mounted on the Top side, B: Mounted on the Bottom side)  
S.=Surface mount

# BOARD LAYOUTS

The combination of top side and bottom side of this page shows the actual configuration of P.C. board.

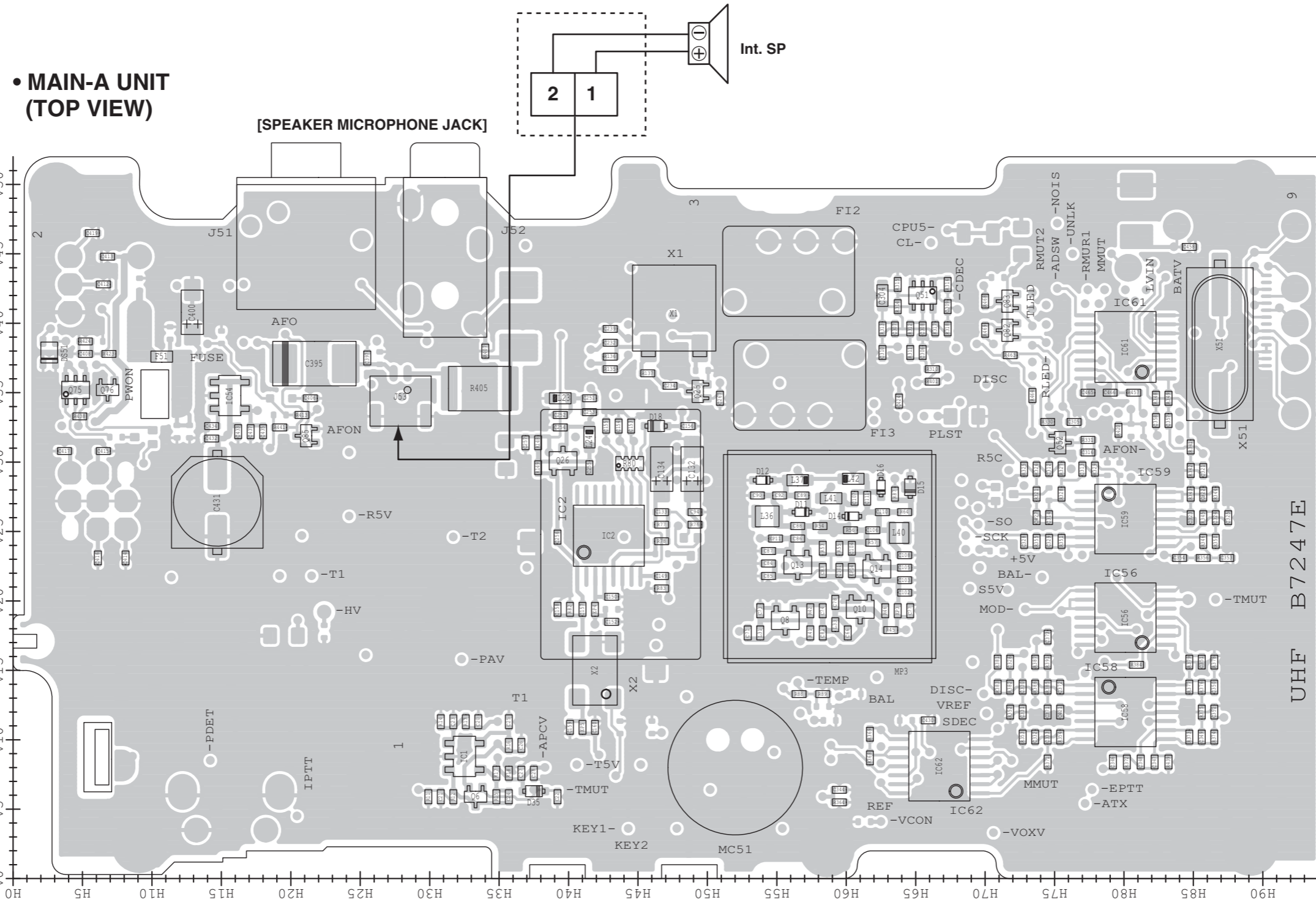



• MAIN-A UNIT  
(BOTTOM VIEW)

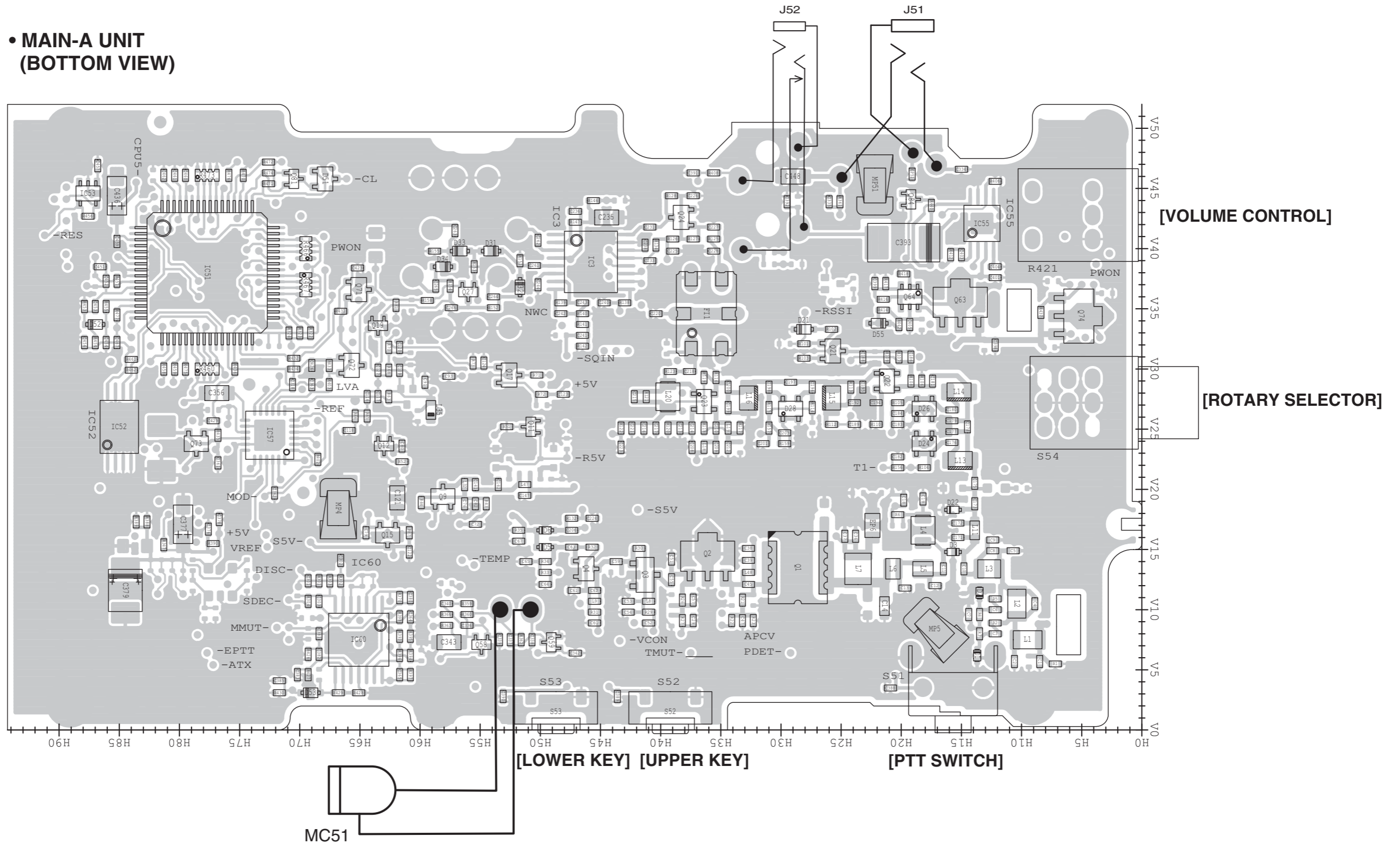

# VOLTAGE DIAGRAM

MAIN-A UNIT (1/2)

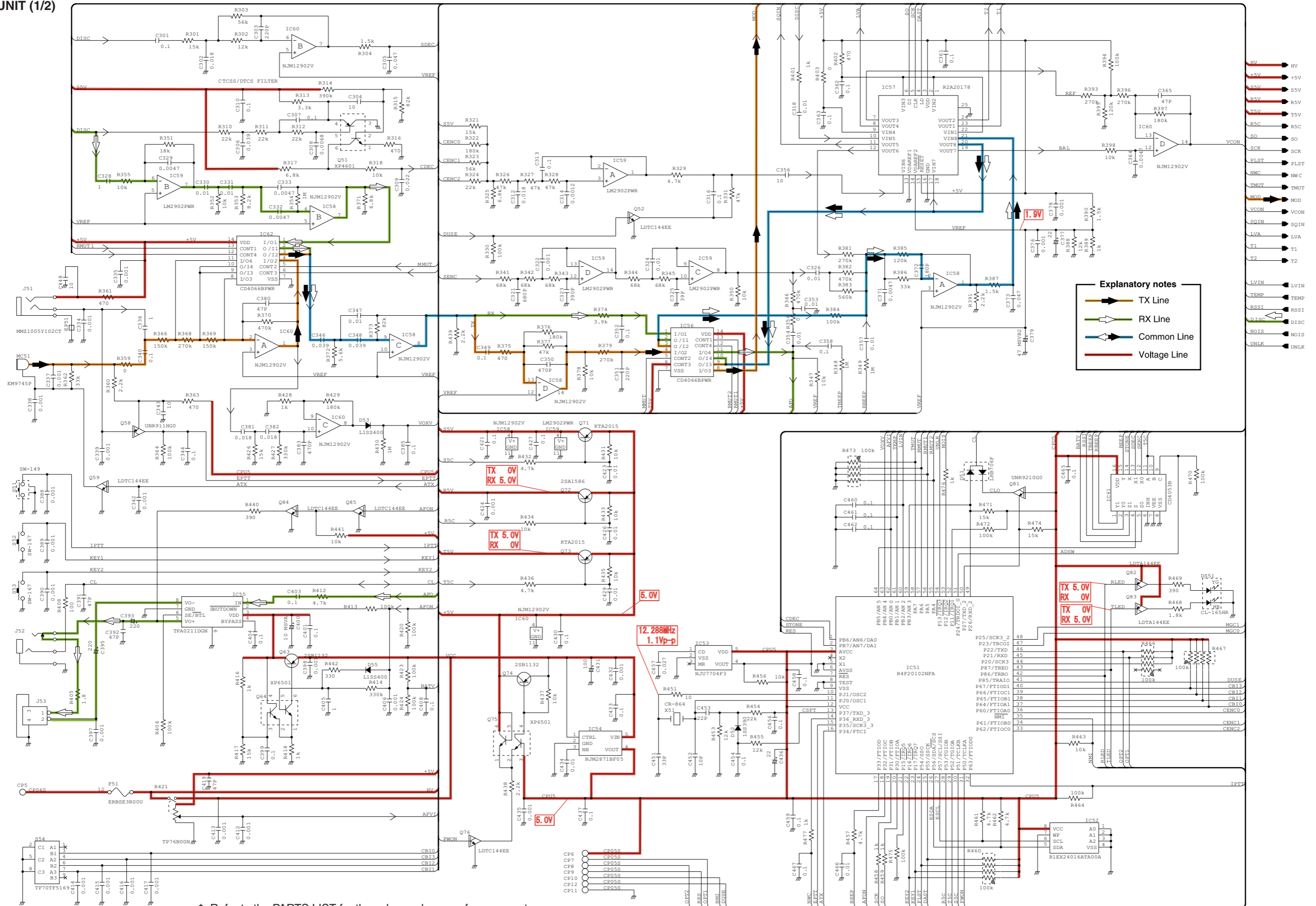

\*: Refer to the PARTS LIST for the value and name of component.

MAIN-A UNIT (2/2)

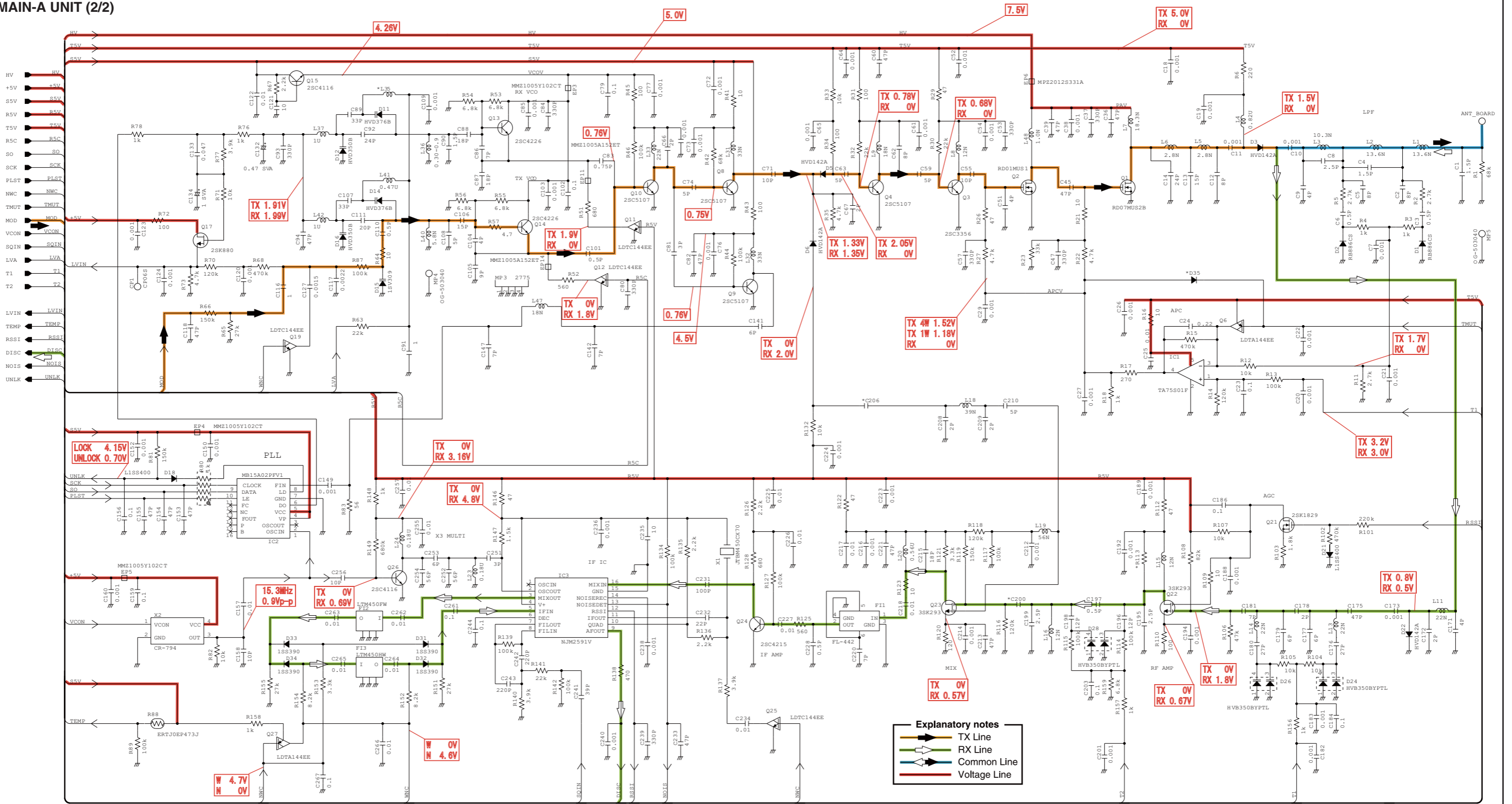

\*: Refer to the PARTS LIST for the value and name of component.



# SERVICE MANUAL

UHF TRANSCEIVERS

**IC-F4001**  
**IC-F4002**  
**IC-F4003**  
**IC-F4006**  
**IC-F4008**

---

---

---

S-14617XZ-C1  
Nov. 2009

Icom Inc.

---

## INTRODUCTION

This service manual describes the latest technical information for the **IC-F4001/IC-F4002/IC-F4003/IC-F4006/IC-F4008 UHF TRANSCEIVERS** at the time of publication.

MODEL	VERSION	CHANNEL SPACING (kHz)	FREQUENCY RANGE (MHz)
IC-F4001	USA-11	12.5/25.0	400–470
	USA-12		
	USA-13		
IC-F4002	EUR-21	12.5/20.0/25.0	
	EUR-22		
	EUR-23		
	UK-01	12.5/25.0	
	UK-02		
	UK-03		
IC-F4003	EXP-11	12.5/25.0	
	EXP-12		
	EXP-13		
	EXP-21		
	EXP-22		
	EXP-23		
	EXP-01		
	EXP-03		
	EXP-31		
	AUS-21		
	AUS-22		
	AUS-23		
	IC-F4006		RUS-21
RUS-22			
RUS-23			
IC-F4008	CHN-31		

To upgrade quality, any electrical or mechanical parts and internal circuits are subject to change without notice or obligation.

## ORDERING PARTS

Be sure to include the following four points when ordering replacement parts:

1. 10-digit Icom part number
2. Component name
3. Equipment model name and unit name
4. Quantity required

### <ORDER EXAMPLE>

1110003491 S.IC TA31136FNG IC-F4001 MAIN UNIT 5 pieces  
8820001210 Screw 2438 screw IC-F4003 Top cover 10 pieces

Addresses are provided on the inside back cover for your convenience.

## CAUTION

**NEVER** connect the transceiver to an AC outlet or to a DC power supply that uses more than the specified voltage. This will ruin the transceiver.

**DO NOT** expose the transceiver to rain, snow or any liquids.

**DO NOT** reverse the polarities of the power supply when connecting the transceiver.

**DO NOT** apply an RF signal of more than 20 dBm (100 mW) to the antenna connector. This could damage the transceiver's front-end.



## REPAIR NOTES

1. Make sure that the problem is internal before disassembling the transceiver.
2. **DO NOT** open the transceiver until the transceiver is disconnected from its power source.
3. **DO NOT** force any of the variable components. Turn them slowly and smoothly.
4. **DO NOT** short any circuits or electronic parts. An insulated tuning tool **MUST** be used for all adjustments.
5. **DO NOT** keep power ON for a long time when the transceiver is defective.
6. **DO NOT** transmit power into a Standard Signal Generator or a Sweep Generator.
7. **ALWAYS** connect a 50 dB to 60 dB attenuator between the transceiver and a Deviation Meter or Spectrum Analyzer when using such test equipment.
8. **READ** the instructions of the test equipment thoroughly before connecting it to the transceiver.

---

## TABLE OF CONTENTS

---

**SECTION 1 SPECIFICATIONS**

**SECTION 2 INSIDE VIEWS**

**SECTION 3 DISASSEMBLY INSTRUCTION**

**SECTION 4 CIRCUIT DESCRIPITON**

4-1	RECEIVER CIRCUITS.....	4-1
4-2	TRANSMITTER CIRCUITS.....	4-2
4-3	FREQUENCY SYNTHESIZER CIRCUITS.....	4-3
4-4	VOLTAGE BLOCK DIAGRAM.....	4-3
4-5	PORT ALLOCATIONS.....	4-4

**SECTION 5 ADJUSTMENT PROCEDURES**

5-1	PREPARATION.....	5-1
5-2	FREQUENCY ADJUSTMENT.....	5-5
5-3	TRANSMIT ADJUSTMENT.....	5-6
5-4	RECEIVE ADJUSTMENT.....	5-7

**SECTION 6 PARTS LIST**

**SECTION 7 MECHANICAL PARTS**

**SECTION 8 BOARD LAYOUTS**

**SECTION 9 BLOCK DIAGRAM**

**SECTION 10 VOLTAGE DIAGRAM**

## ■ GENERAL

• Frequency range	: 400–470 MHz	
• Number of conventional channels	: 16 channels	
• Type of emission	: [EUR] Wide: 16K0F3E (25.0 kHz) Middle: 14K0F3E (20.0 kHz) Narrow: 8K50F3E (12.5 kHz) Except [EUR] Wide: 16K0F3E (25.0 kHz) Narrow: 11K0F3E (12.5 kHz)	
• Antenna impedance	: 50 Ω (Nominal)	
• Operating temperature range	: –30°C to +60°C; –22°F to +140°F –25°C to +55°C	Except [EUR], [UK] [EUR], [UK]
• Power supply voltage	: Specified Icom's battery packs only (7.2 V DC; negative ground)	
• Current drain (Approx.)	: Receiving 70 mA (stand-by) 330 mA (max. audio) Transmitting 1.3 A (at 4.0 W)	
• Dimensions (Projections not included)	: With BP-264 58.6 (W)×111.0 (H)×31.0 (D) mm; 2 5/16 (W)×4 3/8 (H)×1 7/32 (D) in. With BP-265 58.6 (W)×111.0 (H)×35.5 (D) mm; 2 5/16 (W)×4 3/8 (H)×1 13/32 (D) in.	
• Weight	: With BP-264 Approx. 330 g; 11 21/32 oz. With BP-265 Approx. 270 g; 9 17/32 oz.	
• Intermediate frequency	: 1st 46.35 MHz 2nd 450 kHz	
• Output impedance (Audio)	: 8 Ω	
• Input impedance (Audio)	: 2.2 kΩ	

## ■ TRANSMITTER

• Output power	: 4 W	
• Modulation	: Variable reactance frequency modulation	
• Maximum frequency deviation	: Narrow ±2.5 kHz Middle ±4.0 kHz Wide ±5.0 kHz	
• Frequency stability	: ±2.5 ppm	
• Spurious emissions	: 70 dB min. 0.25 μW (≤1 GHz), 1.0 μW (>1 GHz)	Except [EUR], [UK] [EUR], [UK]
• Adjacent channel power	: Narrow 60 dB min., 66 dB typ. Middle 70 dB min., 73 dB typ. Wide 70 dB min., 73 dB typ.	
• Audio harmonic distortion	: Wide, Middle 1.0% typ. at AF 1 kHz 40 % deviation Narrow 1.5% typ. at AF 1 kHz 40 % Deviation	
• FM hum and Noise (Except [EUR], [UK]) (Without CCITT FILTER)	: Narrow 34 dB min., 40 dB typ. Wide 40 dB min., 46 dB typ.	
• Residual modulation ([EUR], [UK]) (With CCITT FILTER)	: Narrow 40 dB min. Middle 43 dB min. Wide 45 dB min.	
• Limiting charact of modulator	: 60–100% of max. deviation	

## ■ RECEIVER

• Sensitivity	: 0.25 $\mu$ V typ. at 12 dB SINAD –4 dB $\mu$ V (EMF) typ. at 20 dB SINAD	Except [EUR], [UK] [EUR], [UK]
• Squelch sensitivity (at threshold)	: 0.25 $\mu$ V typ. –4 dB $\mu$ V (EMF) typ.	Except [EUR], [UK] [EUR], [UK]
• Intermodulation	: 70 dB min. 74 dB typ. 65 dB min.	Except [EUR], [UK] [EUR], [UK]
• Spurious response	: 70 dB min.	
• Audio output power	: 0.8 W typ. at 5% distortion with 12 $\Omega$ (Int. speaker) 0.4 W typ. at 5% distortion with 8 $\Omega$ (Ext. speaker)	
• Hum and noise (Except [EUR], [UK]) (Without CCITT Filter)	: Narrow 34 dB min. 47 dB typ. Wide 40 dB min. 52 dB typ.	
• Hum and noise ([EUR], [UK]) (With CCITT Filter)	: Narrow 40 dB min. Middle 43 dB min. Wide 45 dB min.	
• Adjacent channel selectivity	: Narrow 60 dB min. 65 dB typ. Middle 70 dB min. 73 dB typ. Wide 70 dB min. 73 dB typ.	

Specifications are measured in accordance with TIA/EIA-603B or EN 300 086

**All stated specifications are subject to change without notice or obligation.**



# SECTION 2

# INSIDE VIEWS

## • MAIN-A UNIT (TOP VIEW)

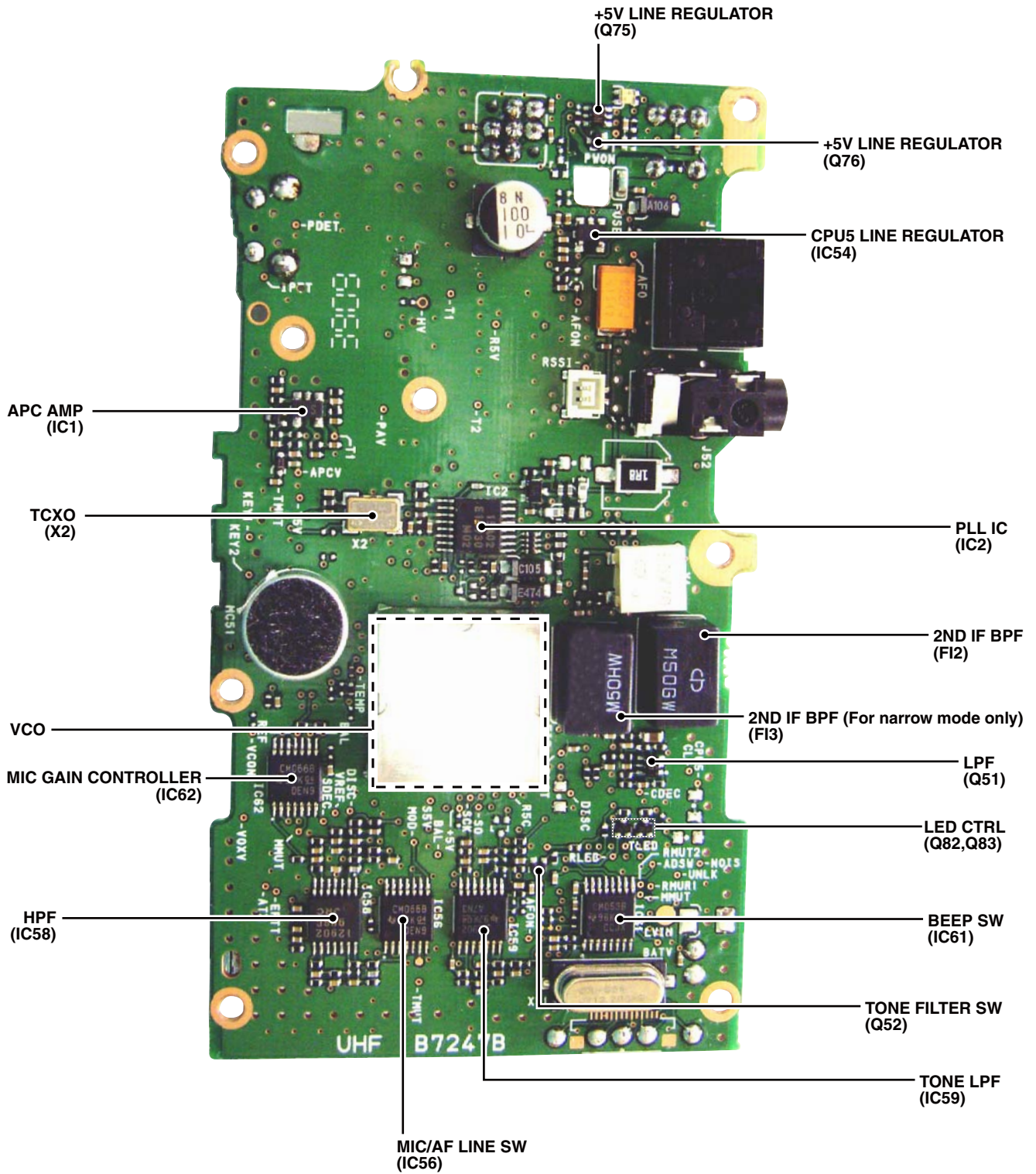

• MAIN-A UNIT  
(BOTTOM VIEW)

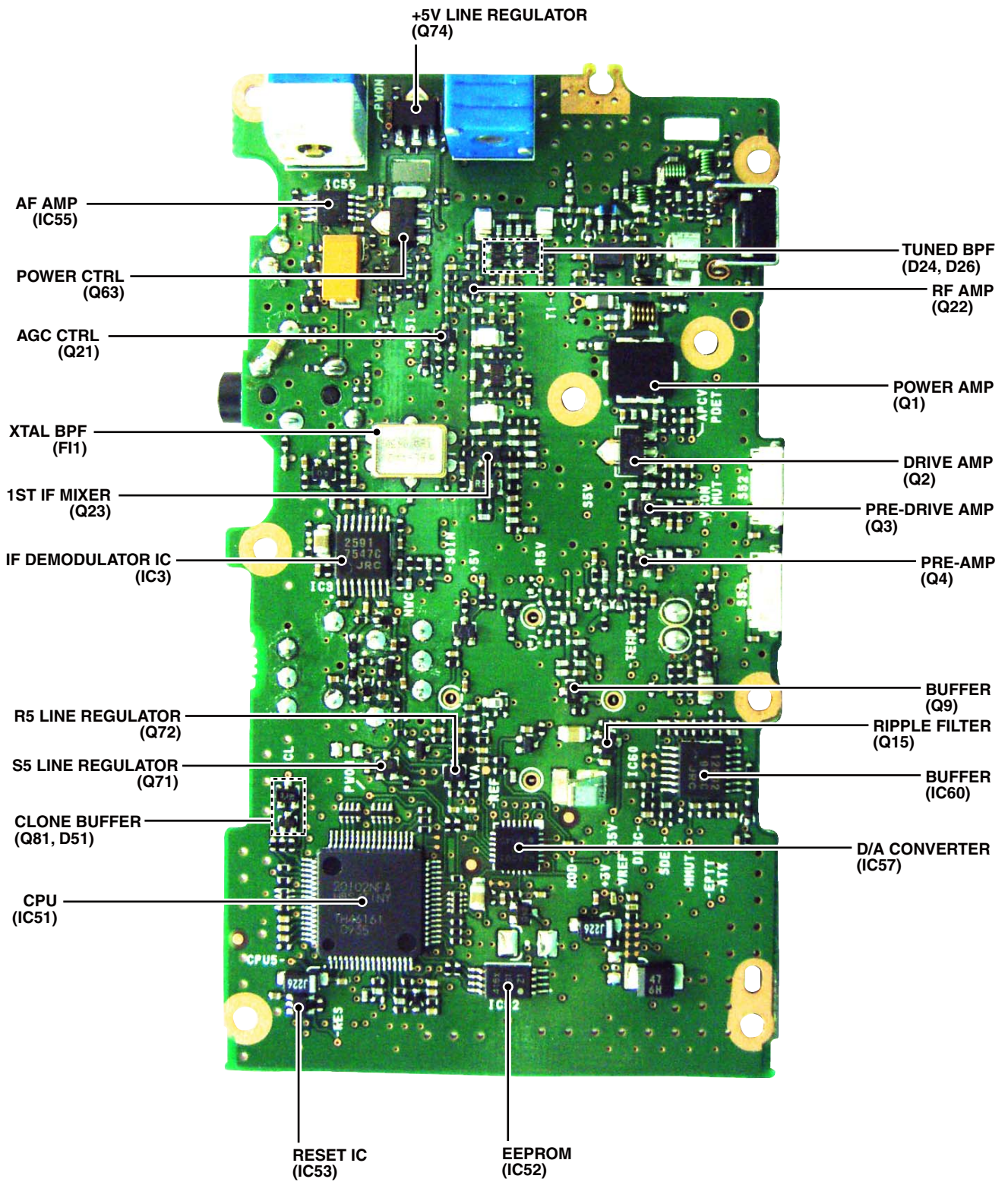

# SECTION 3 DISASSEMBLY INSTRUCTION

## 1. REMOVING THE CHASSIS

1) Remove the ANT connector nut and 2 knobs.

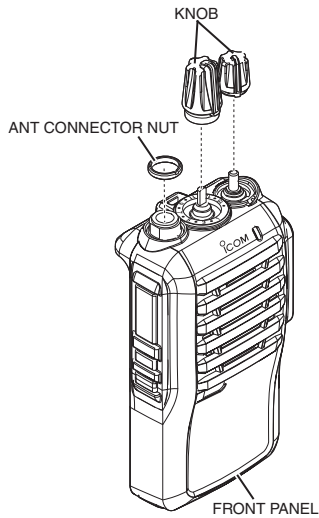

2) Remove 2 screws from the bottom of the CHASSIS.  
3) Lift the bottom of the CHASSIS up in the direction of the arrow.

**BE CAREFUL** to not pull out the **speaker wire** when separating the CHASSIS and the FRONT PANEL.

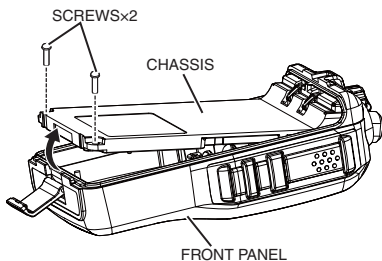

### For easy separation of the CHASSIS

Insert a bolt with matching threads, or similar object that will not cause any damage, into the hollow part of the antenna connector. Use it as the grip to GENTLY lift the bottom of the CHASSIS up slightly.

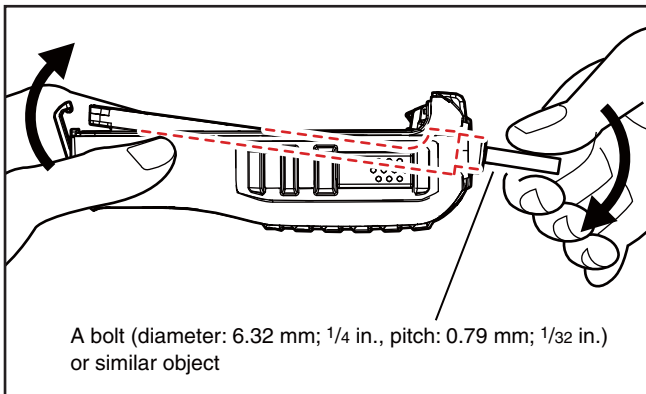

4) CAREFULLY lift the chassis out of the FRONT PANEL and turn it over in order to unplug the speaker wire.

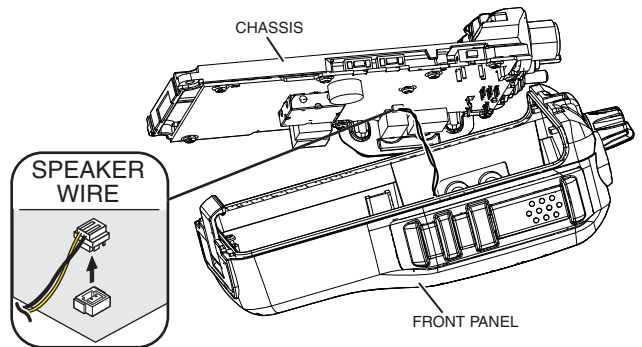

5) Remove the seals and nuts from the CHASSIS.

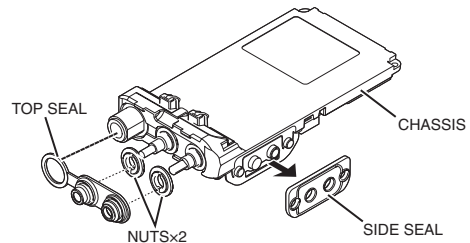

## 2. REMOVING THE MAIN UNIT

1) Remove the 9 screws and the side plate from the MAIN UNIT.  
2) Unsolder the 2 points shown, and then remove the MAIN UNIT.

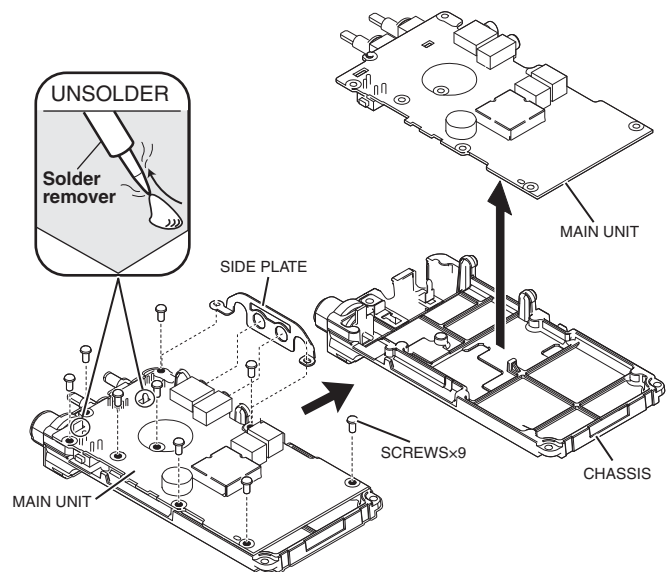

(Continued to the right above)

## 4-1 RECEIVER CIRCUITS

### RF CIRCUITS

The RX signal from the antenna is passed through the LPF and antenna SW, then filtered by the 2-staged tuned BPF to eliminate unwanted out-of-band signal. The filtered RX signal is amplified by the RF AMP, and filtered by another 2-staged tuned BPF to obtain a good image response, then applied to the 1st IF circuits.

The tuned BPFs are tuned to the RX frequency by applying adequate tuning voltages; "T1" and "T2" to the variable capacitors.

### • RF CIRCUITS

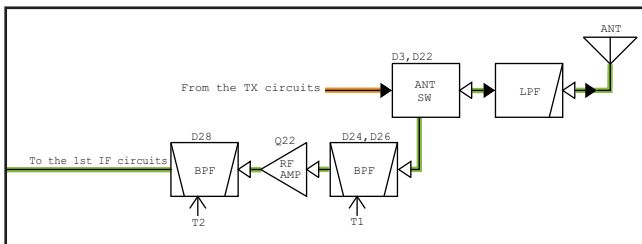

### 1ST IF CIRCUITS

The RX signal from the RF circuits is applied to the 1st IF mixer and mixed with the 1st LO signal from the RX VCO, resulting in the 46.35 MHz 1st IF signal. The 1st IF signal is filtered by the crystal filter, amplified by the 1st IF AMP, then applied to the 2nd IF circuits.

### • 1ST IF CIRCUITS

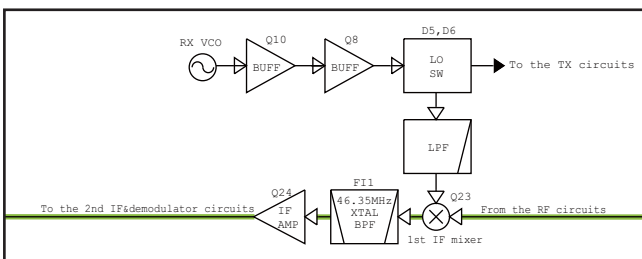

### 2ND IF CIRCUITS AND DEMODULATOR

The signal from the 1st IF circuits is applied to the IF demodulator IC which contains the 2nd IF mixer, 2nd IF AMP, FM detector, etc. in its package.

The 1st IF signal is applied to the 2nd IF mixer and mixed with the 2nd LO signal resulting in the 450 kHz 2nd IF signal.

The 2nd LO signal is generated by tripling the 15.3 MHz reference frequency signal oscillated by the reference frequency oscillator (TCXO).

The converted 2nd IF signal is filtered by the crystal filter/filters to eliminate unwanted signal, and amplified by the 2nd IF AMP, then demodulated by the detector circuit which employs a discriminator as the phase shifter.

The demodulated AF signal is applied to the RX AF circuits.

### • 2ND IF CIRCUITS

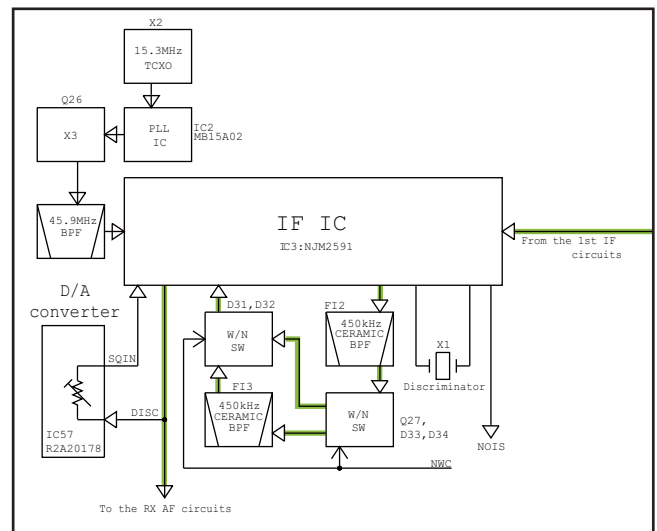

## RX AF CIRCUITS

The demodulated AF signal from the IF demodulator IC is passed through the LPF, HPF which attenuates frequencies 300 Hz and below. The filtered AF signal is passed through the AF line SW, HPF which additionally attenuates frequencies 300 Hz and below, de-emphasis circuit which provides  $-6$  dB/oct of frequency response. The de-emphasized AF signal is passed through the AF SW, LPF which attenuates frequencies 3 kHz and above, is adjusted in level by the D/A converter. The level-adjusted AF signal is then applied to the AF power AMP via the AF line SW.

The amplified AF signal is applied to the internal or external speaker.

### • RX AF CIRCUITS

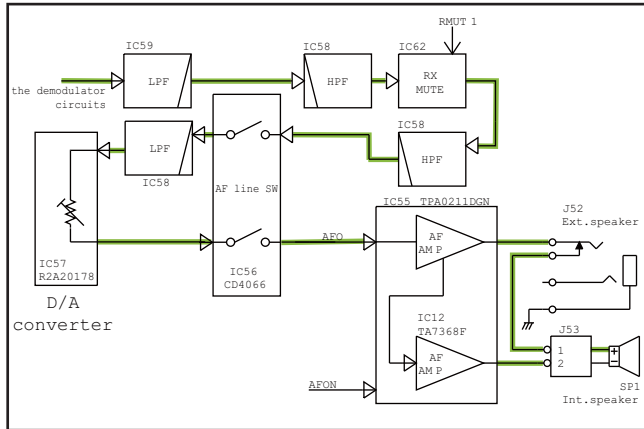

## 4-2 TRANSMITTER CIRCUITS

### TX AF CIRCUITS

The audio signal from the internal or external microphone (MIC signal) is passed through the MIC gain SW and applied to the MIC AMP. The amplified MIC signal is passed through the MIC mute SW, HPF which attenuates frequencies 300 Hz and below. The filtered MIC signal is passed through the pre-emphasis circuit which provides  $+6$  dB/oct of frequency response, then they applied to the limiter AMP.

The amplitude-limited MIC signal is passed through the MIC line SW, and applied to the splatter filter, which attenuate harmonics in the MIC signal to prevent exceeding permissible deviation.

The filtered MIC signal is applied to the D/A converter which adjusts its level (=deviation). The level-adjusted MIC signal is applied to the TX VCO as the modulation signal.

### • TX AF CIRCUITS

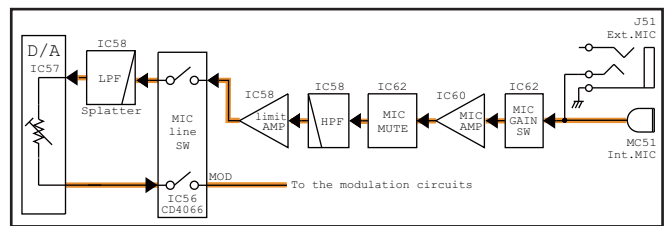

### MODULATION CIRCUIT

The modulation signal from the TX AF circuits is applied to D15 of the TX VCO to frequency-modulate it. The frequency-modulated signal from the TX VCO is buffer-amplified by two buffers, and applied to the TX AMP circuits via the TX/RX SW (D5).

### • MODULATION CIRCUITS

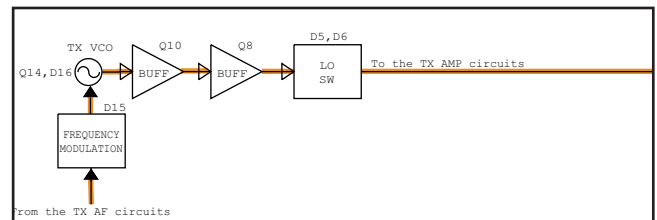

**TX AMPLIFIERS**

The buffer amplified signal from the LO SW (D5) is amplified by; the pre-AMP, pre-drive AMP, drive AMP, and power AMP in sequence, to obtain TX power. The amplified TX signal is passed through the antenna SW and the LPF, which eliminates harmonics, and then fed to the antenna.

**APC CIRCUITS**

D1 and D2 rectify a portion of the TX signal to direct current, and the APC AMP compares the voltage and the TX power control reference voltage, "T1." The resulting voltage controls the gain of the power and drive AMPs to keep the TX power constant.

**• TX AMPLIFIERS AND APC CIRCUIT**

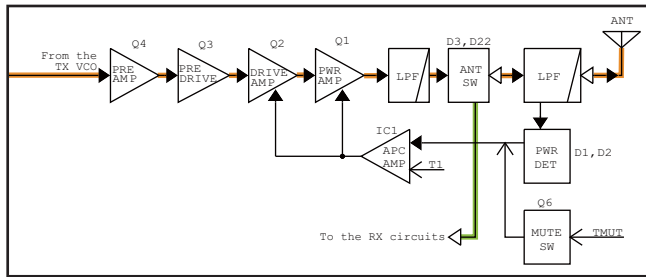

**4-3 FREQUENCY SYNTHESIZER CIRCUITS**

The RX VCO is composed of Q13, D11 and D12. The VCO output signal is buffer-amplified by two buffers and applied to the 1st IF mixer, via the LO SW (D6) and the LPF.

The TX VCO is composed of Q14 and D14–D16. The VCO output signal is buffer-amplified by two buffers and applied to the 1st IF mixer, via the LO SW (D6) and the LPF.

A portion of oscillated signal from each VCO is fed back to the PLL IC via the buffer and the LPF.

The applied VCO output signal is divided and phase-compared with a 15.3 MHz reference frequency signal from the TCXO, which is also divided. The resulting signal is output from the PLL IC, and DC-converted by the loop filter, and then applied to the VCO as the lock voltage.

When the oscillation frequency drifts, its phase changes from that of the reference frequency, causing a lock voltage change to compensate for the drift in the VCO oscillating frequency.

**• FREQUENCY SYNTHESIZER CIRCUITS**

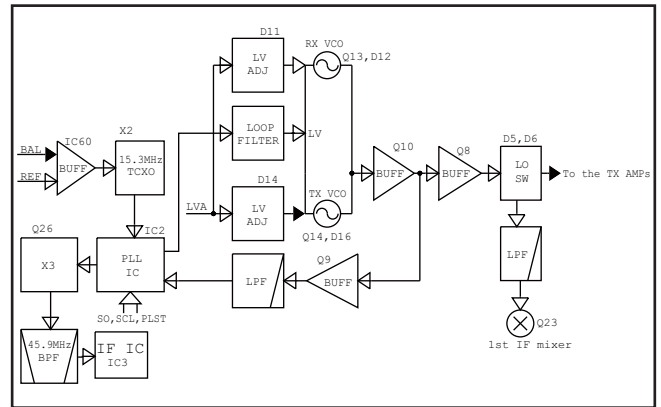

**4-4 VOLTAGE BLOCK DIAGRAM**

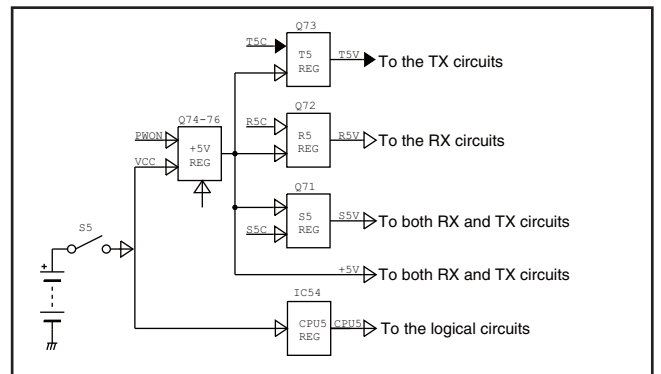

## 4-5 PORT ALLOCATIONS

### • CPU (IC51)

PIN NO.	LINE NAME	DESCRIPTION	I/O
1	CDEC	Tone signal (CTCSS/DTCS) decoding input.	I
2	STONE	Tone signal (5/2 TONE, DTMF, BISS) decoding/encoding .	I/O
13	CSFT	Clock frequency shift. H=Clock frequency is shifted.	O
14	NWC	RX mode (narrow/wide) switching. L=While receiving in the narrow mode	O
15	EPTT	External PTT input. H=An external PTT is pushed.	I
16	ATX	Automatic TX control for VOX mode. H=Microphone input is detected.	O
17	BEEP	Beep sounds. (Square waves)	O
18	AFON	AF power AMP control. H=AF power AMP (IC55) is activated.	O
19	SCK	Common clock.	O
20	SO	Common serial data.	O
22	KEY2	[UPPER] key input. L=Pushed	I
23	KEY1	[LOWER] key input. L=Pushed	I
24	PLST	PLL strobe. H=Load enable.	I/O
25	DAST	D/A converter strobe. H=Load enable.	I/O
26	ESDA	EEPROM data.	I/O
27	ESCL	EEPROM clock.	I/O
28	R5C	Power supply switching control. H=Supplying current to the receiver circuits ("R5"line).	O
29	T5C	Power supply switching control. H=Supplying current to the transmitter circuits ("T5"line).	O
30	S5C	Power supply switching control. H=Supplying current to the RX/ TX common circuits ("S5"line).	O
31	PWON	Power supply switching control. H=The transceiver's power is ON.	O
32	IPTT	Internal PTT input. L=PTT pushed.	I
33, 34, 36	CENC2, CENC1, CENC0	CTCSS/DTCS signal.	O
37-40	CBI0-CBI3	[ROTARY SELECTOR] input.	I
41	DUSE	Frequency response switching. H=DTCS encoding	O
42	RLED	Busy LED (Green) control. L=LED lights. (Squelch open)	O
43	TLED	Busy LED (Red) control. L=LED lights. (Transmit)	O
47	MGC0	MIC gain control.	O
48	MGC1	MIC gain control.	O
49	CLI	Cloning data.	I
50	CLO		O

PIN NO.	LINE NAME	DESCRIPTION	I/O
51	ADSW	A/D conversion select. H=RSSI input, L=BATV input	O
53	NOIS	Noise level detect. H=Squelch close	I
54	UNLK	PLL unlock detect.	I
55	RMUT2	RX AF mute switch control. L=AF mute.	O
56	RMUT1	RX AF mute switch control. L=AF mute.	O
57	MMUT	MIC mute switch control. L=MIC mute.	O
58	TMUT	Transmission mute. L=TX inhibit.	O
59	MDET	External microphone connection detect.	I
60	LVIN	Lock voltage input.	I
61	TEMP	Temperature sensing voltage.	I
62	AFVI	[VOLUME CONTROL] input.	I
63	VOXV	Microphone input sensing voltage.	I
64	AD5	Remaining battery voltage. (or) RSSI voltage. (The input signal depends on the status of pin 51.)	I

### • D/A CONVERTER (IC57)

PIN No.	LINE NAME	DESCRIPTION
23	T1 (TXPO)	BPF tuning voltage TX power control
24	T2	BPF tuning voltage
7	REF	Reference frequency adjust voltage.
8	LVA	Additional lock voltage adjustment.
11	SQLC	Squelch threshold setting.
12	TENC	CTCSS deviation adjustment.
19	BAL	DTCS balance.
20	VRAF	Max. deviation/AF volume adjustment.

# SECTION 5 ADJUSTMENT PROCEDURE

## 5-1 PREPARATION

### REQUIRED EQUIPMENTS

EQUIPMENT	GRADE AND RANGE	EQUIPMENT	GRADE AND RANGE
Cloning software	CS-F3000 CLONING SOFTWARE (Revision 1.0 or later)	JIG cable	Modified OPC-478/U/UC (See the illusted below)
RF power meter (50 Ω terminated)	Measuring range : 0.1–6 W Frequency range : 100–600 MHz SWR : Less than 1.2 : 1	Frequency counter	Frequency range : 0.1–600 MHz Frequency accuracy : ±1 ppm or better Input level : Less than 1 mW
Modulation Analyzer	Frequency range : 30–600 MHz Measuring range : 0 to ±10 kHz	Standard signal generator (SSG)	Frequency range : 0.1–600 MHz Output level : –20 to 90 dBμ (–127 to –17 dBm)
AC millivoltmeter	Measuring range : 10 mV to 10 V		
Oscilloscope	Frequency range : DC–20 MHz Measuring range : 0.01–20 V	Attenuator	Power attenuation : 30 dB Capacity : More than 6 W
Audio generator (AG)	Frequency range : 300–3000 Hz Output level : 1–500 mV	External speaker	Input impedance : 8 Ω Capacity : More than 1 W

### JIG CABLE

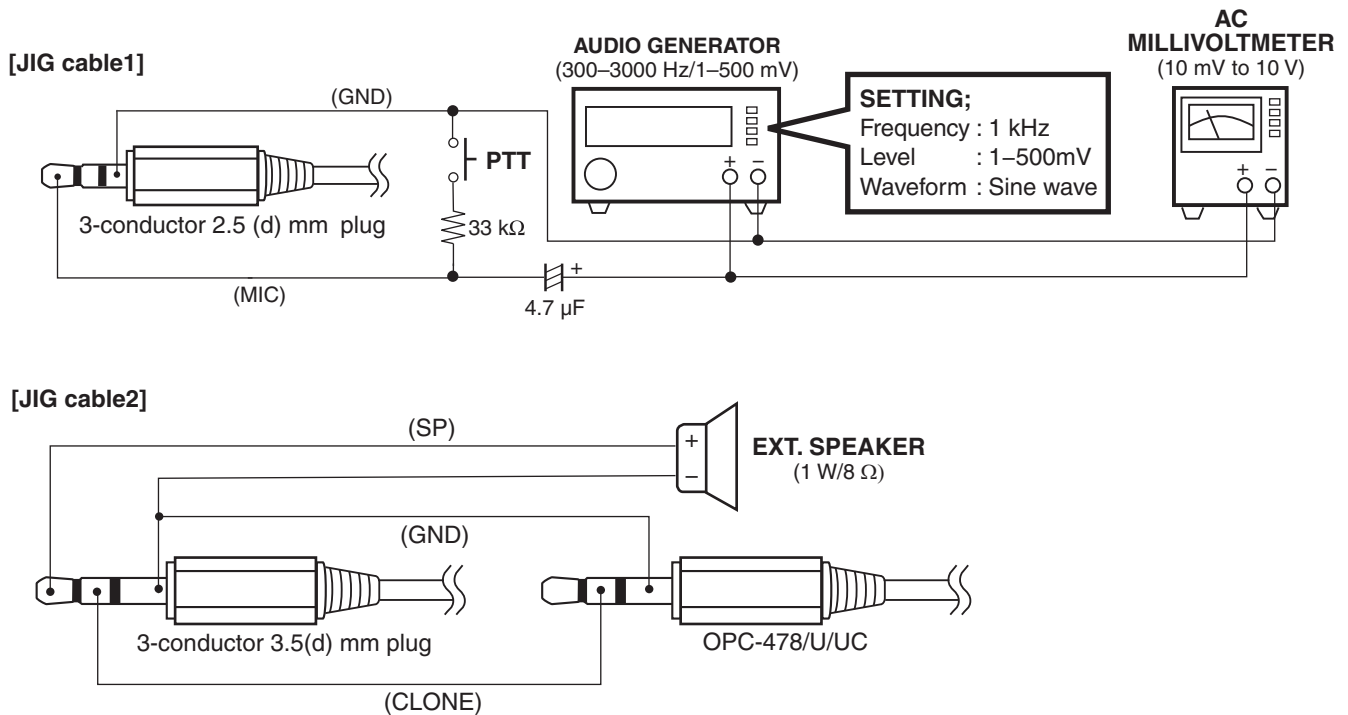



## CONNECTION

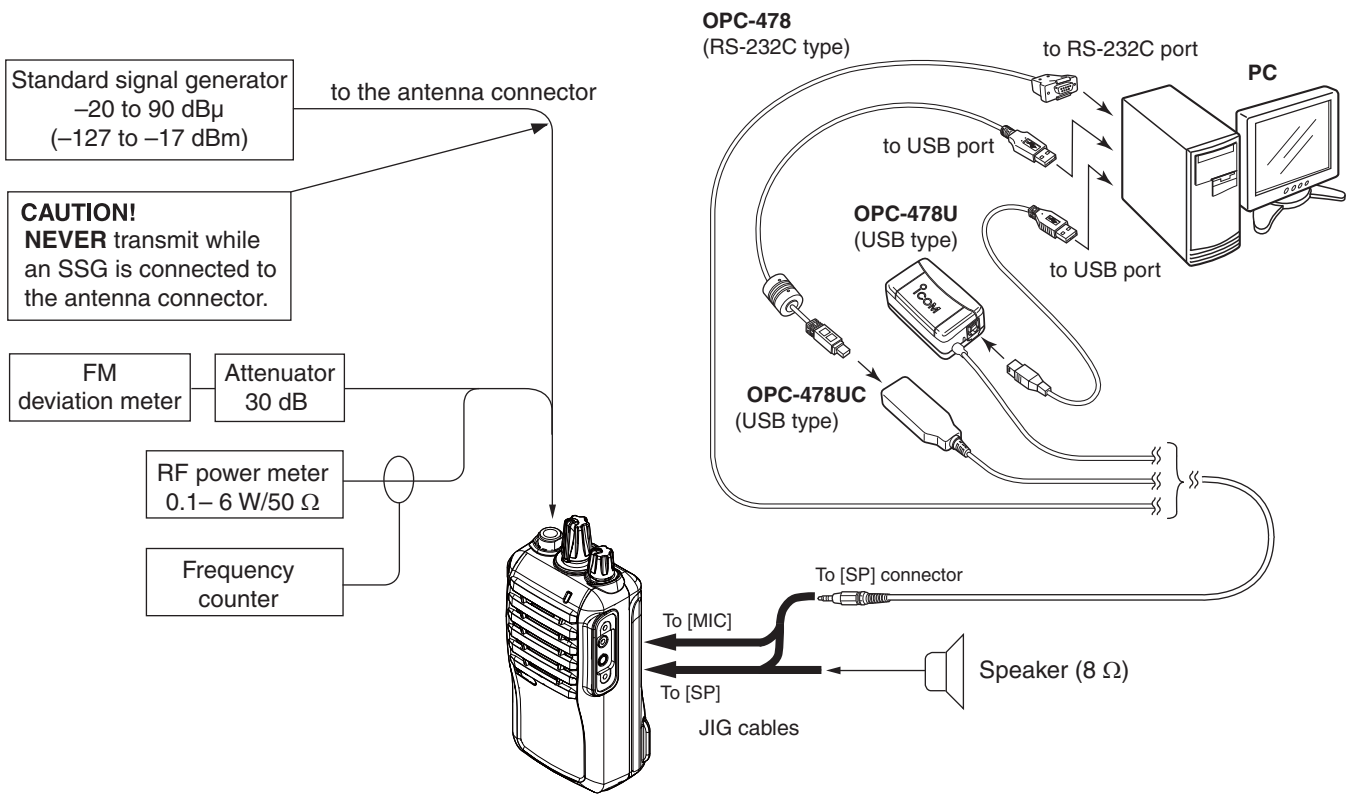

## ADJUSTMENT CHANNELS

Before starting the adjustments, use the cloning software to create the same cloning file as shown below, then upload it into the transceiver.

CH	Atr	Inh	Frequency (MHz)			W/N	SQL Tight	C. Tone			RF PWR	PWR Save	Lock out
			RX	TX	TX Inh			RX	TX	TOT			
1	AB		400.000000	<-		W					L1	ON	
2			470.000000	<-		W					L1	ON	
3			470.000000	<-		W					L1	ON	
4			435.000000	<-		W					H	ON	
5			435.000000	<-		W					L2	ON	
6			435.000000	<-		W					L1	ON	
7			435.000000	<-		W			,007N		L1	ON	
8			435.000000	<-		N					L1	ON	
9			435.000000	<-		W					L1	ON	
10			435.000000	<-		W			,225.7		L1	ON	
11			435.000000	<-		W					L1	ON	
12			400.000000	<-		N					L1	ON	
13													
14													
15													
16													

### CONVENIENT: The same cloning file is available.

Right-click  below, and select "Save Embedded File to Disk."



### For [EUR] versions:

When adjusting "Deviation" in the middle band, change the bandwidth to "Middle" as shown below.

The screenshot shows the software interface for F4000mid.tst - CS-F2000. The 'Others' section is expanded, and the 'Wide Band Width' is set to 'Middle'. A red box highlights the 'Middle' option, with a red arrow pointing to it and the text 'Select "Middle"'. Other settings visible include 'Beat Cancel' set to 'Auto', 'Forced Narrow' set to 'Wide', and 'Forced Narrow Change' set to 'Middle'.

## ADJUSTMENT UTILITY

Click  or [Read <- TR] in the [Adjust] menu to open the "Adjust Utility" window as shown below.

Click to open the "I/O Check window"

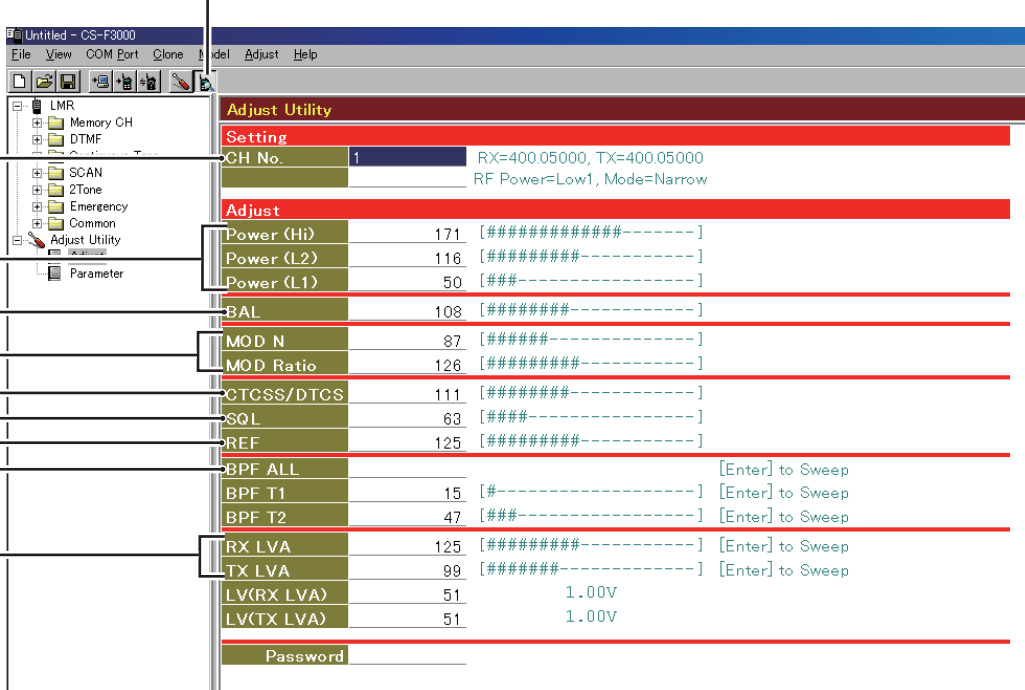

The Adjust Utility window displays a list of parameters for adjustment. The left sidebar shows a tree view with folders for LMR, Memory CH, DTMF, SCAN, 2Tone, Emergency, Common, Adjust Utility, and Parameter. The main window is divided into 'Setting' and 'Adjust' sections. The 'Adjust' section lists parameters with their current values and adjustment ranges.

Parameter	Value	Range	Notes
CH No.	1		RX=400.05000, TX=400.05000 RF Power=Low1, Mode=Narrow
Power (Hi)	171	[#####-----]	
Power (L2)	116	[#####-----]	
Power (L1)	50	[###-----]	
BAL	108	[#####-----]	
MOD N	87	[#####-----]	
MOD Ratio	126	[#####-----]	
CTCSS/DTCS	111	[#####-----]	
SQL	63	[####-----]	
REF	125	[#####-----]	
BPF ALL			[Enter] to Sweep
BPF T1	15	[#-----]	[Enter] to Sweep
BPF T2	47	[###-----]	[Enter] to Sweep
RX LVA	125	[#####-----]	[Enter] to Sweep
TX LVA	99	[#####-----]	[Enter] to Sweep
LV(RX LVA)	51		1.00V
LV(TX LVA)	51		1.00V
Password			

If the below window appears, the utility is password-protected. Enter the password to open the "Adjust Utility" window.

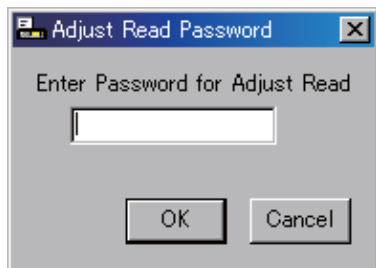

## 5-2 FREQUENCY ADJUSTMENTS

- 1) Select an adjustment item using [↑]/[↓] on the PC's keyboard.
- 2) Set or modify the adjustment value as specified using [←]/[→] on the PC's keyboard, then push [ENTER].

ADJUSTMENT	TRANSCEIVER'S CONDITION	OPERATION	ADJUSTMENT ITEM	VALUE
PLL LOCK VOLTAGE -Adjustment-	1	-	-	-
(RX)	2 • CH. : 1 • Receiving	• Select the item [RX LVA], then push [ENTER].	[RX LVA]	1.0 V
(TX)	3 • CH. : 1 • Transmitting	• Select the item [TX LVA], then push [ENTER].	[TX LVA]	1.0 V
PLL LOCK VOLTAGE -Verify- (RX)	1 • CH. : 2 • Receiving	• Click the [Reload (F5)] button to check on the "I/O Check window" as illustrated below.	[LVIN] (On the "I/O Check window")	3.0–4.0 V (Verify)
(TX)	2 • CH. : 2 • Transmitting			2.7–3.9 V (Verify)
REFERENCE FREQUENCY	1 • CH. : 3 • Transmitting	• Loosely couple a frequency counter to the antenna connector.	[REF]	470.0000 MHz (±300 Hz)

### • I/O Check window

Input	Dec	Hex	Data
VIN	215	D7	8.43V
TEMPS	189	BD	31.75°C
LVIN	48	30	*** v
SD	30	1E	0.59V

Output	Dec	Hex	Data
T1/POW	15	F	0.29V
BPF T2	47	2F	0.92V
REF	130	82	2.55V
MOD BAL	0	0	0.00%
Dev	0	0	0.00V
CTCSS	91	5B	1.78V
SQL Lev	0	0	0.00V
LVA	125	7D	2.45V

Lock voltage

(The values shown above are example only.  
Each transceiver has own values.)

### 5-3 TRANSMIT ADJUSTMENTS

- 1) Select an adjustment item using [↑]/[↓] on the PC's keyboard.
- 2) Set or modify the adjustment value as specified using [←]/[→] on the PC's keyboard, then push [ENTER].

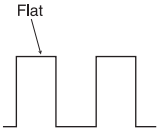
ADJUSTMENT	TRANSCEIVER'S CONDITION	OPERATION	ADJUSTMENT ITEM	VALUE
<b>TX OUTPUT POWER (Hi power)</b>	1 • CH. : 4 • Transmitting	• Connect an RF power meter to the antenna connector.	<b>[Power (Hi)]</b>	4.0 W
<b>(L2 power)</b>	2 • CH. : 5 • Transmitting		<b>[Power (L2)]</b>	2.0 W
<b>(L1 power)</b>	3 • CH. : 6 • Transmitting		<b>[Power (L1)]</b>	1.0 W
<b>MODULATION BALANCE</b>	1 • CH. : 7 • Transmitting	• Connect a modulation analyzer with an oscilloscope to the antenna connector through an attenuator.	<b>[BAL]</b>	Square waveform 
<b>FM DEVIATION (Narrow mode)</b>	1 • CH. : 8 • Transmitting	• Connect a modulation analyzer to the antenna connector through an attenuator.	<b>[MOD N C]</b>	±2.05 to ±2.15 kHz
<b>(Middle mode)*</b>	2 • CH. : 9 • Transmitting		<b>[MOD M C]</b>	±3.25 to ±3.35 kHz
<b>(Wide mode)</b>	3 • CH. : 9 • Transmitting		<b>[MOD W C]</b>	±4.05 to ±4.15 kHz
<b>CTCSS/DTCS DEVIATION</b>	1 • CH. : 10 • Transmitting	• Connect a modulation analyzer to the antenna connector through an attenuator.	<b>[CTCSS/DTCS]</b>	±0.65 to ±0.75 kHz

\*; [EUR] versions only

## 5-4 RECEIVE ADJUSTMENTS

1) Select an adjustment item using [ $\uparrow$ ]/[ $\downarrow$ ] on the PC's keyboard.

2) Set or modify the adjustment value as specified using [ $\leftarrow$ ]/[ $\rightarrow$ ] on the PC's keyboard, then push [ENTER].

ADJUSTMENT		TRANSCIVER'S CONDITION	OPERATION	ADJUSTMENT ITEM	VALUE
RX SENSITIVITY	1	<ul style="list-style-type: none"> <li>• CH. : 11</li> <li>• Receiving</li> </ul>	1) Connect an SSG to the antenna connector and set it as; Frequency : 435 MHz Level* : 20 dB $\mu$ (-87 dBm) Modulation : 1 kHz Deviation : $\pm$ 3 kHz 2) Put the cursor on the adjustment item, then push [ENTER].	[BPF ALL]	(Automatic adjustment)
SQUELCH	1	<ul style="list-style-type: none"> <li>• CH. : 12</li> <li>• Receiving</li> </ul>	1) Connect an SSG to the antenna connector and set it as; Frequency : 400 MHz Level* : -13 dB $\mu$ (-120 dBm) Modulation : 1 kHz Deviation : $\pm$ 1.5 kHz 2) Once close the squelch by increasing [SQL] value, then decrease the value to open the squelch. 3) Push [ENTER] key to store the value.	[SQL]	(Automatic adjustment)

\*; The output level of the standard signal generator (SSG) is indicated as the SSG's open circuit.









[MAIN-A UNIT]

REF NO.	PARTS NO.	DESCRIPTION	M.	H/V LOCATION
C391	4030011320	S.CER C1005 CH 1H 470J-T	B	37.3/46.3
C393	4520000020	S.NIO NOJC227M006	B	19.8/40.9
C395	4520000020	S.NIO NOJC227M006	T	21.7/37.1
C397	4030019740	S.CER C1005 JB 1H 102K-T	T	26/36.5
C398	4030019740	S.CER C1005 JB 1H 102K-T	B	12.2/32
C399	4030019930	S.CER C1005 JB 1A 104K-T	B	22.2/37.1
C400	4550006250	S.TAN TEESVA 1A 106M8R	T	12.9/40.8
C401	4030019930	S.CER C1005 JB 1A 104K-T	B	12.2/37.6
C403	4030019930	S.CER C1005 JB 1A 104K-T	B	15.8/39.6
C404	4030019930	S.CER C1005 JB 1A 104K-T	B	12.2/38.5
C405	4030019970	S.CER C1005 JB 0J 105K-T	B	19.3/33.7
C406	4030019740	S.CER C1005 JB 1H 102K-T	T	20.7/32.2
C408	4030019930	S.CER C1005 JB 1A 104K-T	T	5.2/37.8
C410	4030019740	S.CER C1005 JB 1H 102K-T	T	11.3/39.3
C412	4030019740	S.CER C1005 JB 1H 102K-T	T	6.5/42.8
C413	4030019740	S.CER C1005 JB 1H 102K-T	T	6.8/44.8
C414	4030019740	S.CER C1005 JB 1H 102K-T	T	8.1/23.1
C415	4030019740	S.CER C1005 JB 1H 102K-T	T	6.5/30.8
C416	4030019740	S.CER C1005 JB 1H 102K-T	T	6.1/23.1
C417	4030019740	S.CER C1005 JB 1H 102K-T	T	3.7/30.8
C421	4030019930	S.CER C1005 JB 1A 104K-T	T	75.4/12
C423	4030019810	S.CER C1005 JB 1E 103K-T	B	65.2/38.4
C424	4030019740	S.CER C1005 JB 1H 102K-T	T	63.8/34.4
C426	4030019810	S.CER C1005 JB 1E 103K-T	B	69/30.3
C427	4030019930	S.CER C1005 JB 1A 104K-T	T	73.7/26
C429	4030019810	S.CER C1005 JB 1E 103K-T	B	77.2/25.7
C430	4030019930	S.CER C1005 JB 1A 104K-T	T	65.9/11.4
C431	4510009870	S.ELE 10 CE 100 LD	T	14.7/27.1
C432	4030019740	S.CER C1005 JB 1H 102K-T	T	14.3/31.7
C433	4030019930	S.CER C1005 JB 1A 104K-T	T	16.2/32.2
C434	4030019810	S.CER C1005 JB 1E 103K-T	T	14.3/32.6
C435	4030019740	S.CER C1005 JB 1H 102K-T	T	18/32.2
C436	4550007320	S.TAN F930J226MAABMA	B	85.2/44.4
C437	4030019930	S.CER C1005 JB 1A 104K-T	T	17.1/32.2
C451	4030009790	S.CER C1005 CH 1H 330J-T	B	86.6/38.5
C452	4030009740	S.CER C1005 CH 1H 100C-T	B	86.1/37.3
C453	4030009770	S.CER C1005 CH 1H 220J-T	B	87/35.2
C454	4030019930	S.CER C1005 JB 1A 104K-T	B	86.1/32.2
C456	4030019930	S.CER C1005 JB 1A 104K-T	B	87.9/32.2
C457	4030019870	S.CER C1005 JB 1A 273K-T	B	86.8/46.9
C458	4030019930	S.CER C1005 JB 1A 104K-T	T	84.7/45.5
C459	4030019930	S.CER C1005 JB 1A 104K-T	B	85.2/40.6
C460	4030019930	S.CER C1005 JB 1A 104K-T	B	79.5/46.1
C461	4030019930	S.CER C1005 JB 1A 104K-T	B	80.4/46.1
C462	4030019930	S.CER C1005 JB 1A 104K-T	B	81.3/46.1
C465	4030019930	S.CER C1005 JB 1A 104K-T	T	77.4/35
C466	4030019810	S.CER C1005 JB 1E 103K-T	T	79/35
C467	4030019930	S.CER C1005 JB 1A 104K-T	B	85.2/32.2
J51	6450000131	CON HSJ1102-018540		
J52	6450002250	CON HSJ1456-010320		
J53	6510021901	S.CON BM02B-ASRS-TF(LF)(SN)	T	30.5/34.5
F51	5210000970	S.FUS ERBSE3R00U	T	10.7/37.6
DS51	5040002670	S.LED CL-165HR/YG	T	2.6/37.9
MC51	7700002920	MIC EM9745P-38-G-01 <HOR>		
S51	2260001900	SWI SW-149 (SKHLLD)		
S52	2260002800	S.SWI SW-167 (SKQTLAE010)	B	39.2/1.8
S53	2260002800	S.SWI SW-167 (SKQTLAE010)	B	48.7/1.8
S54	2250000670	ENC TP70TF5169-15.9F-3285		
EP3	6910018460	S.BEA MMZ1005Y102C-T	T	63.7/19.3
EP4	6910018460	S.BEA MMZ1005Y102C-T	T	41.9/19.4
EP5	6910018460	S.BEA MMZ1005Y102C-T	T	41/10.9
EP6	6910014730	S.BEA MPZ2012S331A-T	B	22.4/17
EP11	6910021240	S.BEA MMZ1005A152ET	T	54.9/24.5
EP14	6910021240	S.BEA MMZ1005A152ET	T	60.4/22.2
EP51	6910018460	S.BEA MMZ1005Y102C-T	B	20.3/46.6
MP3	8510016471	S.CAS 2775 VCO CASE-1	T	58.8/23.2
MP4	6910014760	S.PLA OG-503040	B	66.8/18.4
MP5	6910014760	S.PLA OG-503040	B	17.9/9.5

M.=Mounted side (T: Mounted on the Top side, B: Mounted on the Bottom side)  
S.=Surface mount

# SECTION 7

# MECHANICAL PARTS

## [CHASSIS PARTS]

REF NO.	ORDER NO.	DESCRIPTION	QTY.
J1	6910021491	ANT CONNECTOR 106-1	1
SP1	2510001560	045P01202-02	1
W1	8900009640	OPC-963	1
EP1	0910065992	B-7262B	1
MP1	8010021710	3285 CHASSIS	1
MP2	8210026010	3285 FRONT PANEL (Incl. MP3-9)	1
MP3	8210025830	3285 PTT PANEL	1
MP4	8930080110	3285 PTT BUTTON	1
MP5	8930080130	3285 PTT RUBBER	1
MP6	8930079890	3285 LOCK PLATE	1
MP7	8210025800	3285 BOTTOM PANEL	1
MP8	8930080380	3285 SHAFT	1
MP9	8930080180	SP NET (F)	1
MP10	8930080170	3285 NAME SHEET	1
MP11	8930080120	3285 LENS	1
MP12	8930080620	O-RING (CF)	1
MP13	8930080630	3285 SP PLATE	1
MP14	8930042350	1922 MIC SHEET	1
MP15	8930080410	3285 MIC SPONGE	1
MP16	8930079900	3285 TERMINAL HOLDER	1
MP17	8930080100	3285 PLUS TERMINAL	1
MP18	8930080400	3285 MINUS TERMINAL	1
MP19	8930069710	THERMALLY SHEET (BC)	1
MP20	8830003390	VR NUT (AB)	2
MP21	8930080090	3285 SIDE PLATE	1
MP22	8930080150	3285 SIDE SEAL	1
MP23	8930080140	3285 TOP SEAL	1
MP24	8830003440	3285 ANT NUT	1
MP25	8610014180	KNOB N-389 (Incl. MP26)	1
MP26	8610007510	KNOB SPRING NO.7800	1
MP27	8610014190	KNOB N-390	1
MP28	8610007920	KNOB SPRING NO.1500	1
MP31	8810008761	SCREW BT B0 2X8 NI-ZC3 (BT)	2
MP32	8810009511	SCREW BT B0 2X4 NI-ZC3 (BT)	9
MP33	8810009511	SCREW BT B0 2X4 NI-ZC3 (BT)	1
MP34	8810009181	OTAP 1FLAT WASHER B0 2X5 NI-ZC3 (BT)	2

## [MAIN-A UNIT]

REF NO.	ORDER NO.	DESCRIPTION	QTY.
J51	6450000131	HSJ1102-018540	1
J52	6450002250	HSJ1456-010320	1
J53*	6510021901	BM02B-ASRS-TF (LF) (SN)	1
MC51	7700002920	EM9745P-38-G-01	1
S51	2260001900	SW-149 (SKHLLD)	1
S52*	2260002800	SW-167 (SKQT)	1
S53*	2260002800	SW-167 (SKQT)	1
S54	2250000670	TP70TF5169-15.9F-3285	1
MP2	8510016461	2775 VCO COVER-1	1
MP3*	8510016471	2775 VCO CASE-1	1
MP4*	6910014760	OG-503040	1
MP5*	6910014760	OG-503040	1
MP6	8930080760	SPONGE (KT)	1
MP7	8930080770	INSULATION SHEET (MQ)	1

## [ACCESSORIES]

REF NO.	ORDER NO.	DESCRIPTION	QTY.
EP1	(Optional)	FA-SC57U-1	1
EP2	(Optional)	BP-264 EXP [USA-11], [USA-12], [EUR-21], [EUR-22], [UK-01], [UK-02], [EXP-11], [EXP-12], [EXP-21], [EXP-22], [EXP-01], [AUS-21], [AUS-22], [RUS-21], [RUS-22]	1
	(Optional)	BP-265 [USA-13], [EUR-23], [UK-03], [EXP-13], [EXP-23], [EXP-03], [AUS-23], [RUS-23]	1
EP3	(Optional)	BC-191 EXP [USA-11], [EUR-21], [UK-01], [EXP-11], [EXP-21], [AUS-21], [RUS-21]	1
	(Optional)	BC-192 EXP [USA-12], [EUR-22], [UK-02], [EXP-12], [EXP-22], [AUS-22], [RUS-22]	1
	(Optional)	BC-193 EXP [USA-13], [EUR-23], [UK-03], [EXP-13], [EXP-23], [AUS-23], [RUS-23]	1
EP4	(Optional)	BC-123SA (L) [USA-11], [USA-13], [EUR-22], [EXP-11], [EXP-13], [EXP-22], [RUS-22]	1
	(Optional)	BC-147SA [USA-12], [USA-12], [EXP-12]	1
	(Optional)	BC-123SE (L) [EUR-21], [EUR-23], [EXP-21], [EXP-23], [RUS-21], [RUS-23]	1
	(Optional)	BC-123SV (L) [AUS-21], [AUS-23], [RUS-23]	1
	(Optional)	BC-147SV [AUS-22]	1
MP1	(Optional)	MB-124	1
MP2	8210025840	3285 JACK PANEL	1
MP3	8810004861	SCREW PH M2X6 ZK3	2

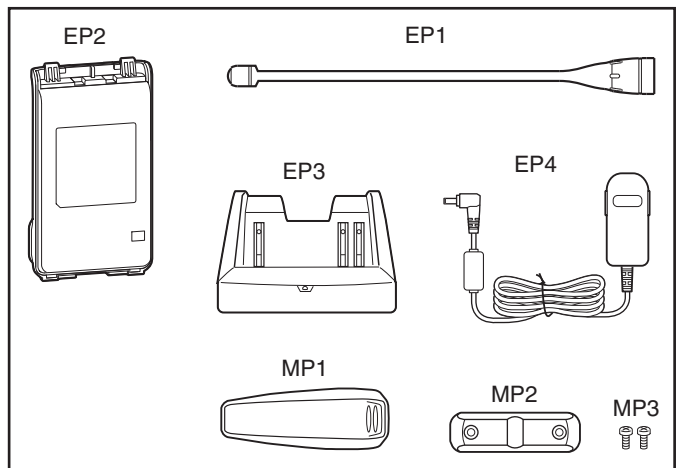

\*: Refer to "BOARD LAYOUTS" for the location.

**Screw abbreviations** A, B0, BT: Self-tapping PH: Pan head ZK: Black NI-ZU: Nickel-Zinc SUS: Stainless

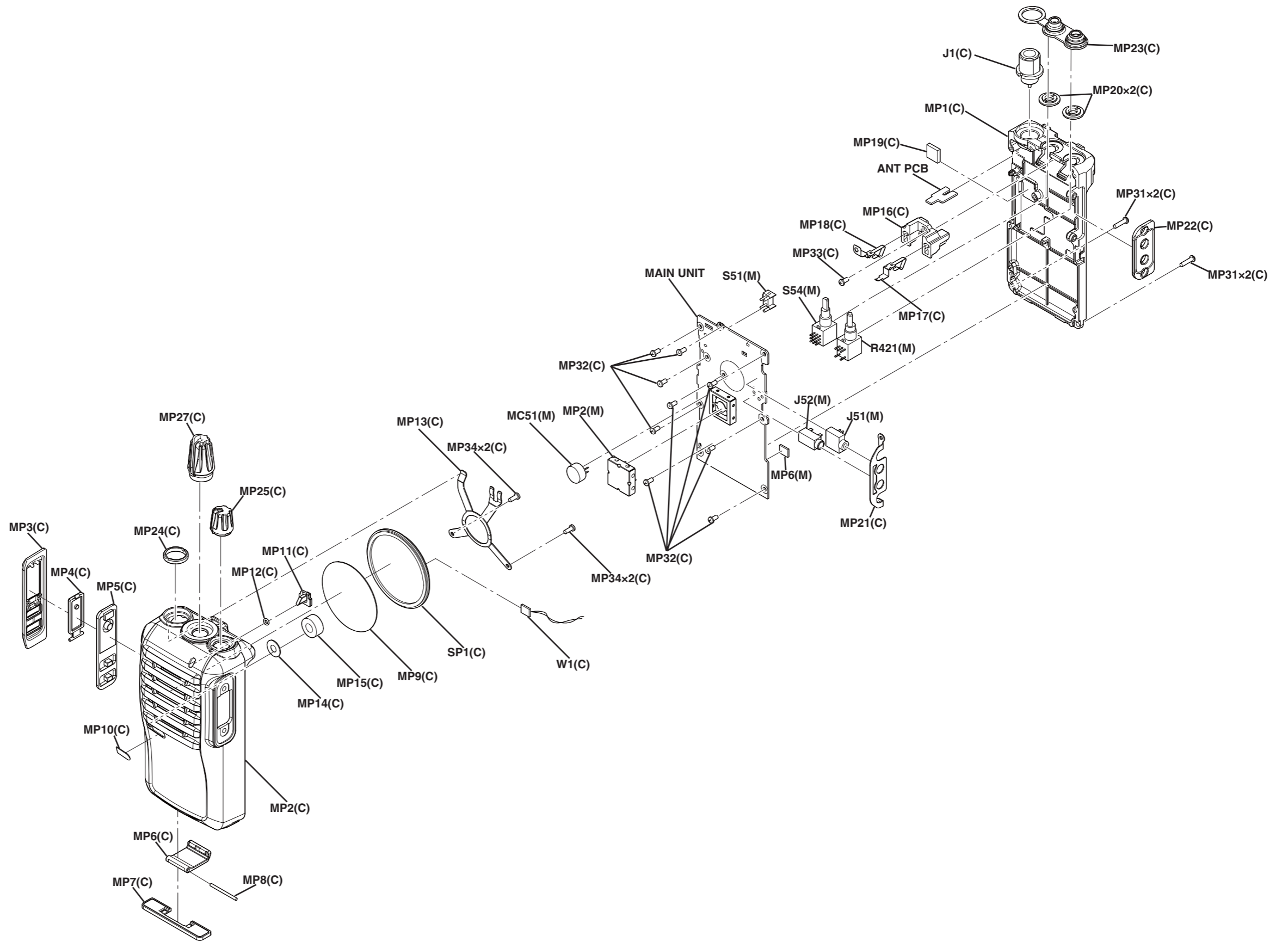

**UNIT ABBREVIATIONS**  
 (C): CHASSIS PARTS  
 (M): MAIN-A UNIT

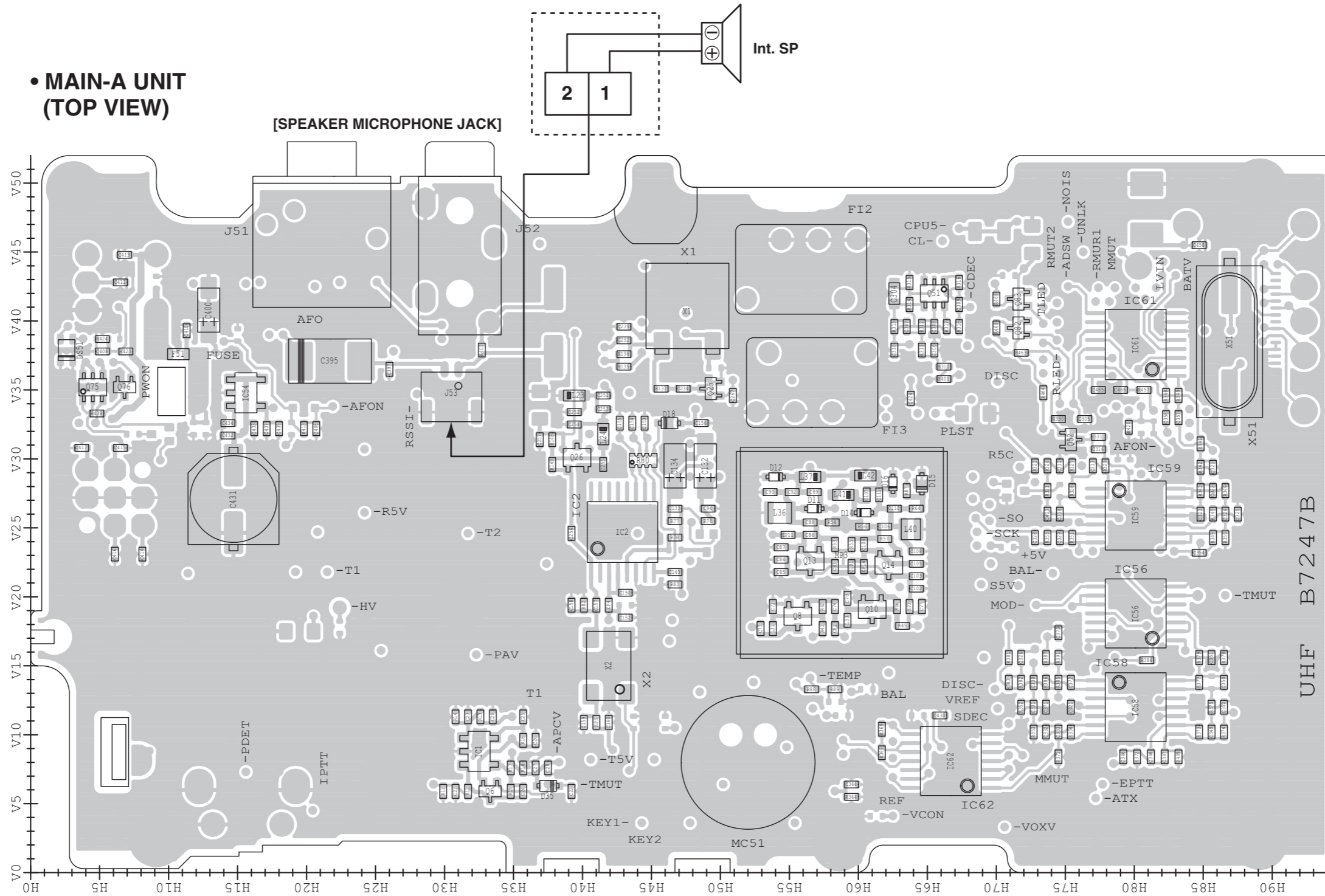

• MAIN-A UNIT  
(BOTTOM VIEW)

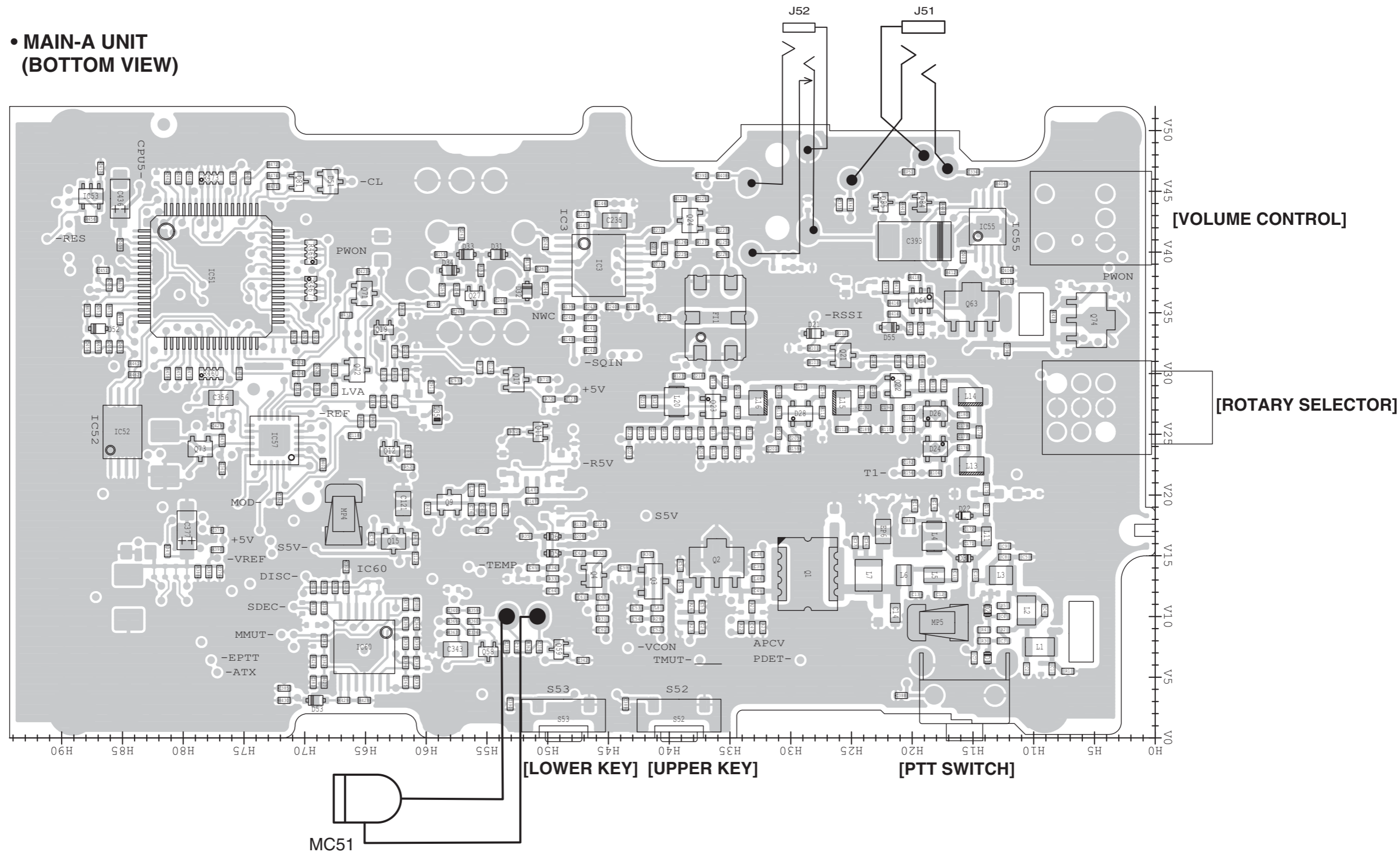

# SECTION 9

# BLOCK DIAGRAM

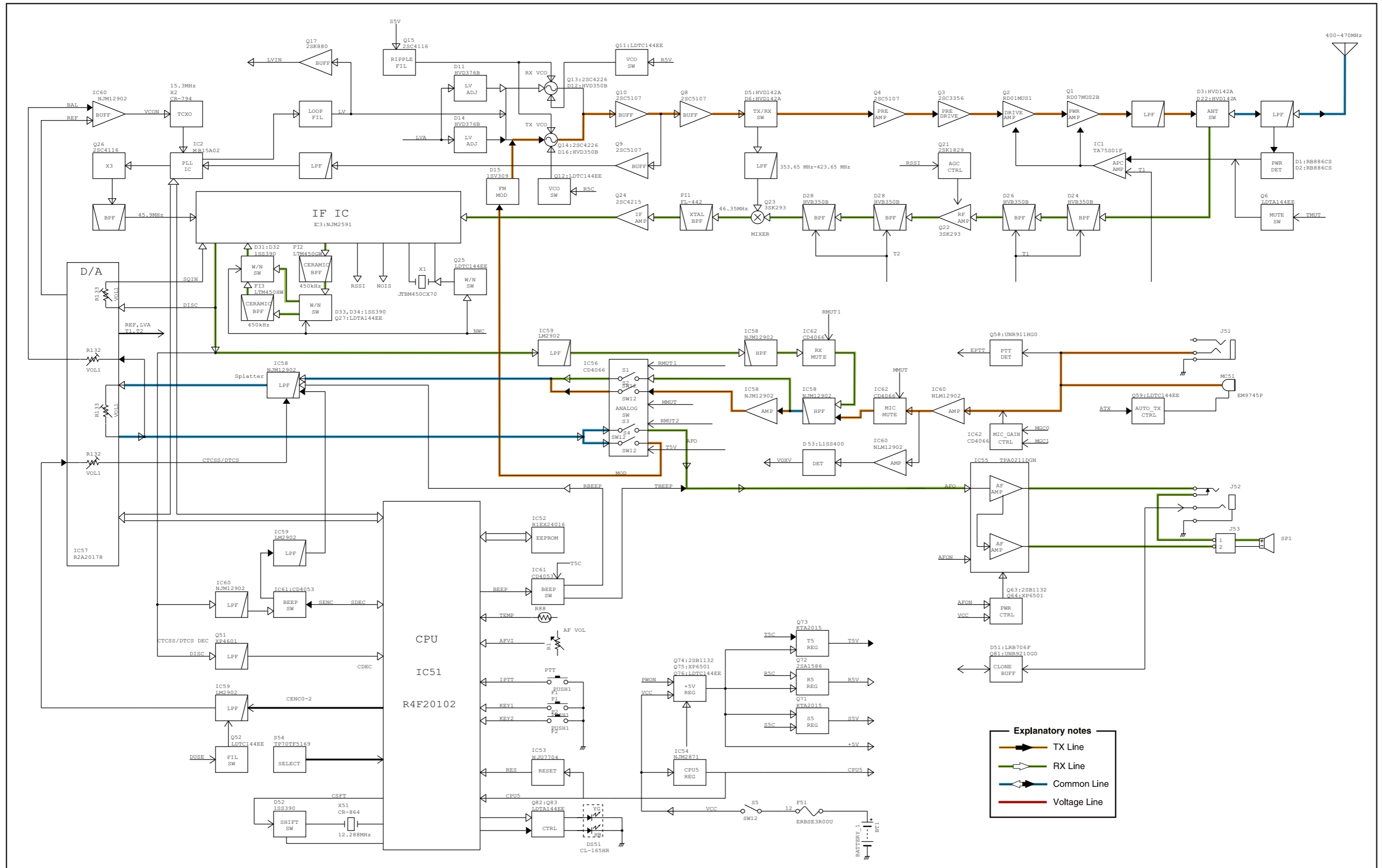

# SECTION 10

# VOLTAGE DIAGRAM

MAIN-A UNIT (1/2)

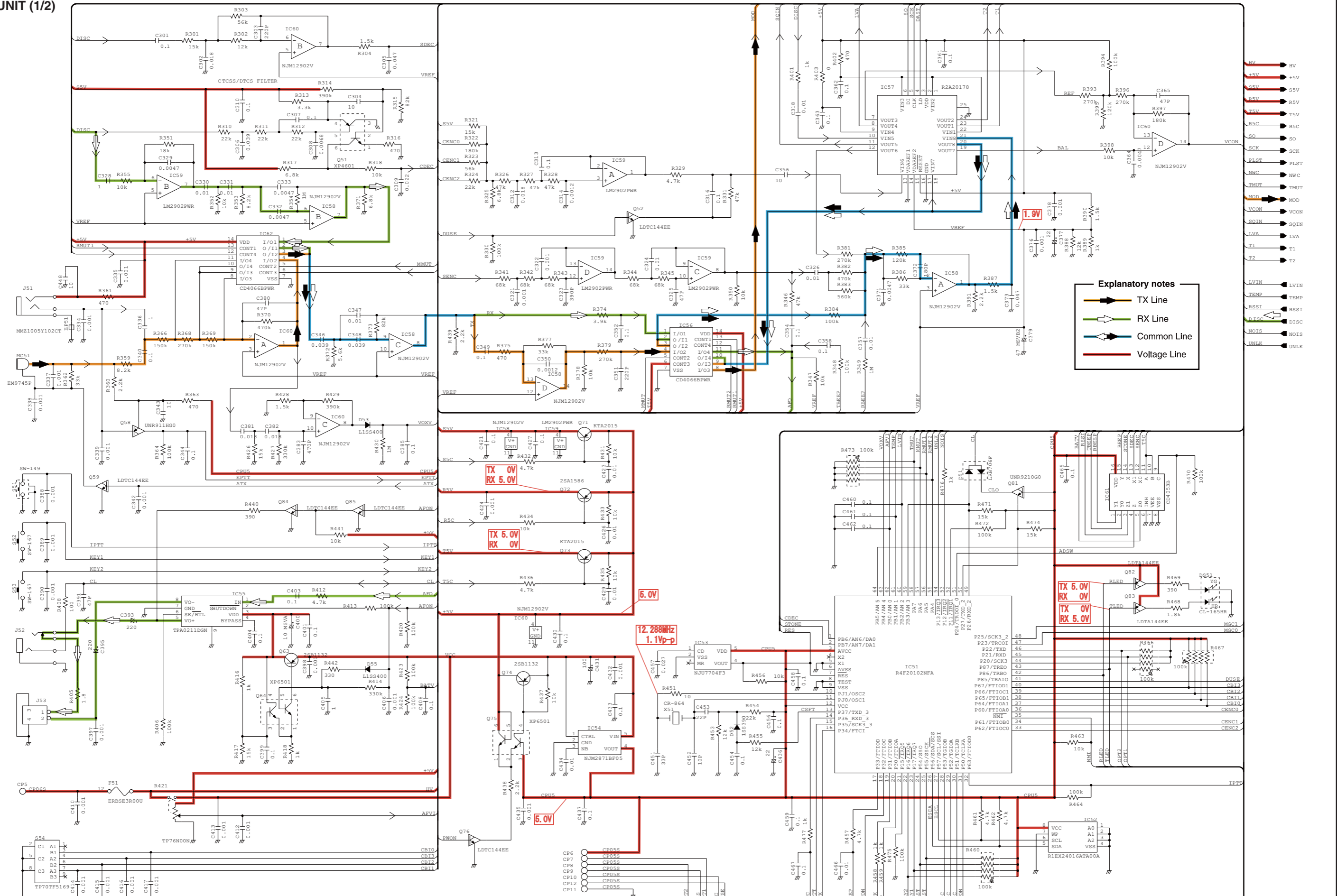

**Explanatory notes**

- TX Line
- RX Line
- Common Line
- Voltage Line

\*: Refer to the PARTS LIST for the value and name of component.



MAIN-A UNIT (2/2)

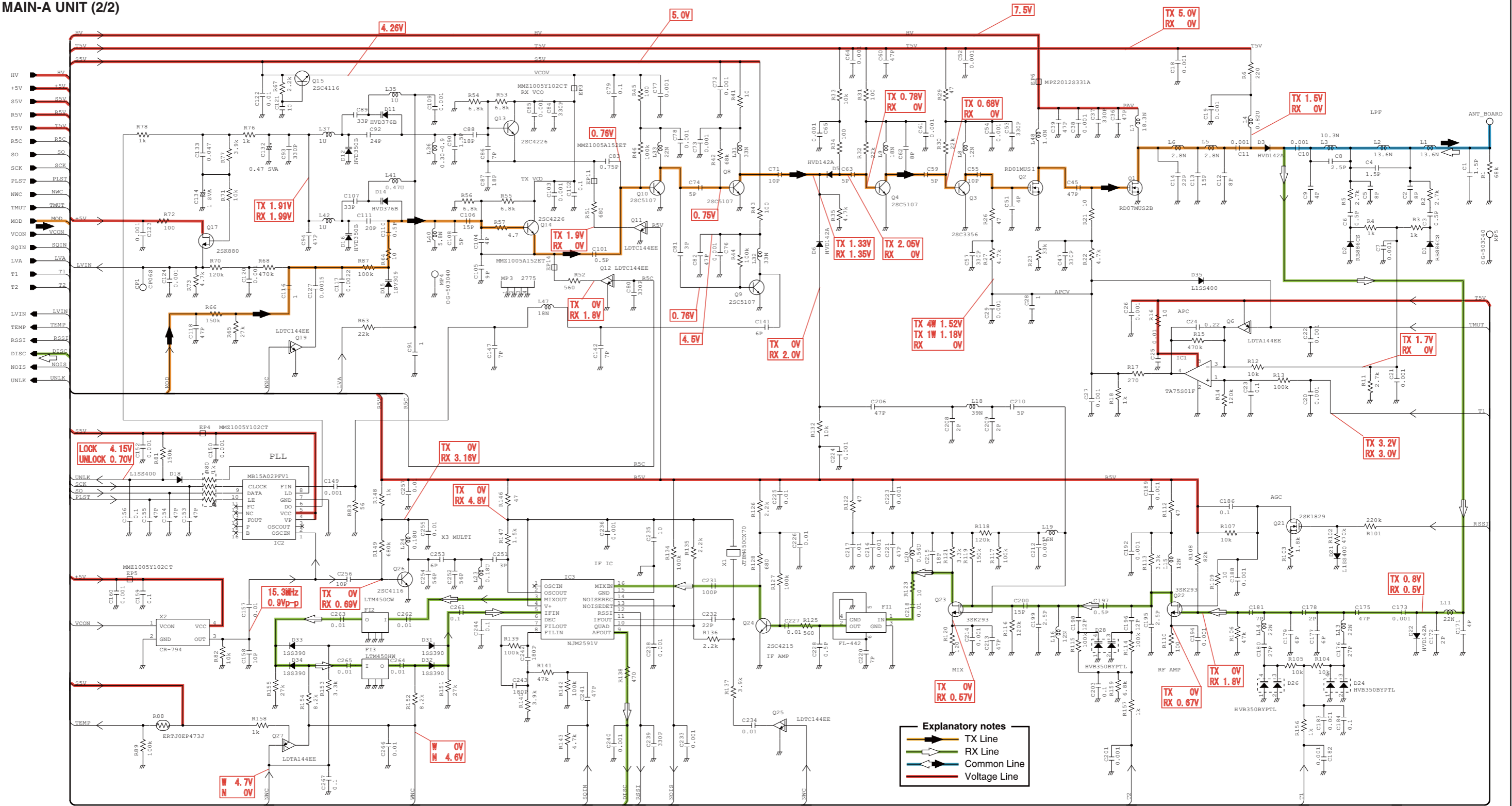

\*: Refer to the PARTS LIST for the value and name of component.

## Icom Inc.

1-1-32, Kamiminami, Hirano-ku, Osaka 547-0003, Japan  
Phone : +81 (06) 6793 5302  
Fax : +81 (06) 6793 0013  
URL : <http://www.icom.co.jp/world/index.html>

### Icom America Inc.

<Corporate Headquarters>  
2380 116th Avenue N.E., Bellevue, WA 98004, U.S.A.  
Phone : +1 (425) 454-8155 Fax : +1 (425) 454-1509  
URL : <http://www.icomamerica.com>  
E-mail : [sales@icomamerica.com](mailto:sales@icomamerica.com)  
<Customer Service>  
Phone : +1 (425) 454-7619

### Icom Canada

Glenwood Centre #150-6165  
Highway 17 Delta, B.C., V4K 5B8, Canada  
Phone : +1 (604) 952-4266 Fax : +1 (604) 952-0090  
URL : <http://www.icomcanada.com>  
E-mail : [info@icomcanada.com](mailto:info@icomcanada.com)

### Icom (Australia) Pty. Ltd.

Unit 1 / 103 Garden Road, Clayton VIC 3168 Australia  
Phone : +61 (03) 9549-7500 Fax : +61 (03) 9549-7505  
URL : <http://www.icom.net.au>  
E-mail : [sales@icom.net.au](mailto:sales@icom.net.au)

### Icom New Zealand

146A Harris Road, East Tamaki,  
Auckland, New Zealand  
Phone : +64 (09) 274 4062 Fax : +64 (09) 274 4708  
URL : <http://www.icom.co.nz>  
E-mail : [inquiries@icom.co.nz](mailto:inquiries@icom.co.nz)

### Beijing Icom Ltd.

10C07, Long silver Mansion, No.88, Yong Ding  
Road, Haidian District, Beijing, 100039, China  
Phone : +86 (010) 5889 5391/5392/5393  
Fax : +86 (010) 5889 5395  
E-mail : [bjicom@bjicom.com](mailto:bjicom@bjicom.com)  
URL : <http://www.bjicom.com>

### Icom (Europe) GmbH

Communication Equipment  
Auf der Krautweide 24  
65812 Bad Soden am Taunus, Germany  
Phone : +49 (6196) 76685-0 Fax : +49 (6196) 76685-50  
URL : <http://www.icomeurope.com>  
E-mail : [info@icomeurope.com](mailto:info@icomeurope.com)

### Icom Spain S.L

Ctra. Rubi, No. 88 Bajos A 08174, Sant Cugat del Valles, Barcelona, Spain  
Phone : +34 (93) 590 26 70 Fax : +34 (93) 589 04 46  
URL : <http://www.icomspain.com>  
E-mail : [icom@icomspain.com](mailto:icom@icomspain.com)

### Icom (UK) Ltd.

Blacksole House, Altira Park, Herne Bay, Kent CT6 6GZ, UK  
Phone : +44 (01227) 741741 Fax : +44 (01227) 741742  
URL : <http://www.icomuk.co.uk>  
E-mail : [info@icomuk.co.uk](mailto:info@icomuk.co.uk)

### Icom France s.a.s.

Zac de la Plaine  
1 Rue Brindejone des Moulinais BP 5804  
31505 Toulouse Cedex, France  
Phone : +33 (5) 61 36 03 03 Fax : +33 (5) 61 36 03 00  
URL : <http://www.icom-france.com>  
E-mail : [icom@icom-france.com](mailto:icom@icom-france.com)

### Asia Icom Inc.

6F No.68, Sec. 1 Cheng-Teh Road, Taipei, Taiwan, R.O.C.  
Phone : +886 (02) 2559 1899 Fax : +886 (02) 2559 1874  
URL : <http://www.asia-icom.com>  
E-mail : [sales@asia-icom.com](mailto:sales@asia-icom.com)

### Icom Polska

81-850 Sopot, ul. 3 Maja 54, Poland  
Phone : +48 (58) 550 7135 Fax : +48 (58) 551 0484  
E-mail : [icompolska@icompolska.com.pl](mailto:icompolska@icompolska.com.pl)

**Count on us!**

**Icom Inc.**

1-1-32, Kamiminami, Hirano-ku, Osaka 547-0003, Japan

S-14617XZ-C1  
© 2009 Icom Inc.